



P.L. LIGHT SYSTEMS

THE LIGHTING KNOWLEDGE COMPANY

T: 905.563.4133

Toll Free: 1.800.263.0213

F: 905.563.0445

www.plight.com



FIXTURE	HSE NXT-LP
Project	
Notes	



TECHNICAL SPECIFICATIONS†		1000W			
RATED MAIN VOLTAGE		208V	240V	277V	347V
Input Current		5.10A	4.42A	3.77A	3.01A
Power Factor		50/60Hz			
Input Frequency		50/60Hz			
Actual Input Power		1,060W	1,060W	1,045W	1,045W
Lamp Type		HPS 1000W 400V Electronic			

†Accurate to ± 10%

TECHNICAL SPECIFICATIONS†		600W	
RATED MAIN VOLTAGE		277V	347V
Input Current		2.29A	1.84A
Power Factor		>0.98	
Input Frequency		50/60Hz	
Actual Input Power		630W	
Lamp Type		HPS 600W 400V Electronic	

†Accurate to ± 10%

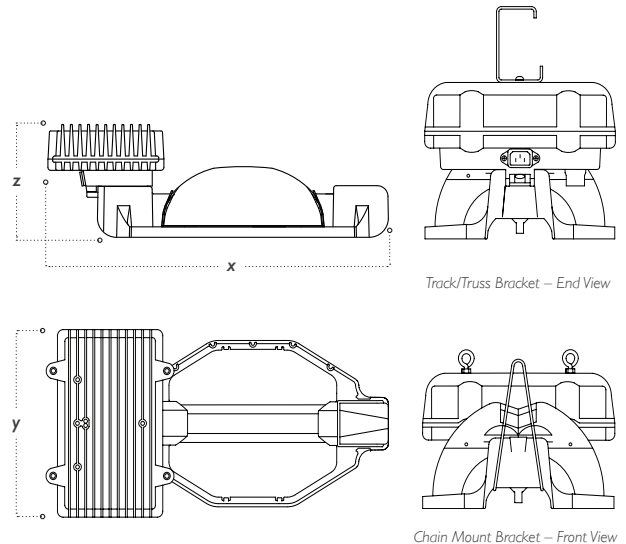

DIMENSIONS	
	Alpha/Beta
x = length	21.50 in. (54.61 cm)
y = width	11.00 in. (27.94 cm)
z = height	7.50 in. (19.05 cm)
weight	10.00 lb. (4.54 kg)



For maximum lifetime and performance of the HPS ballast and lamp, do not rapidly cycle luminaire on and off. Always observe 15-30 minute wait time when luminaire is turned off before applying power again (restrike) to allow lamp to cool sufficiently. The control system should be limited to 2 power-up (strikes) / day. Excessive strikes / day may decrease the life of the ballast and/or lamp.

SPECIFICATION						
1. FIXTURE	2. FIXTURE WATTAGE	3. VOLTAGE	4. LIGHT SOURCE	5. REFLECTOR	6. CORD / PLUG	7. MOUNTING
NXT-LP RST	600 Watts [†] 1000 Watts	208V [*] 240V [*] 277V 347V	600W USHIO HPS DBL 1000W PL Light HPS DBL 1000W Philips HPS DBL 1000W USHIO HPS DBL	Alpha Beta	Consult Factory	NXT-LP 2" x 1" Truss Bracket NXT-LP 1-5/8" Track Bracket
	[†] special order only	[*] 1000W only				

Warranty Terms: Fixtures warranted for four (4) years; electronic drivers four (4) years; HPS Lamps four (4) years or 10,000 burning hours, whichever comes first. Complete system four (4) year warranty period applies to product configurations with factory standard P.L. Light Systems' ballast ONLY. Warranty period may vary for configurations with ballast and/or lamp by other manufacturers.