

User Manual

Green
Field



Green Field

Irrigation Controller

Ag/MIS/UmEN-2732-05/19 Rev 1.2

116782

 **Munters**

Green Field

User manual

Rev 1.2, 05/2022

This manual for use and maintenance is an integral part of the apparatus together with the attached technical documentation.

This document is destined for the user of the apparatus: it may not be reproduced in whole or in part, committed to computer memory as a file or delivered to third parties without the prior authorization of the assembler of the system.

Munters reserves the right to effect modifications to the apparatus in accordance with technical and legal developments.

Index

| <i>chapter</i> | | <i>page</i> |
|----------------|--|-------------|
| 1 | INTRODUCTION | 6 |
| 1.1 | Disclaimer | 6 |
| 1.2 | Introduction | 6 |
| 1.3 | Notes | 6 |
| 2 | GENERAL INFORMATION | 7 |
| 2.1 | Keyboard | 7 |
| 2.2 | Hot Screens | 7 |
| 2.3 | Main Menu Icons | 8 |
| 2.4 | Introduction to Irrigation Programs | 8 |
| 2.5 | Operation Mode | 9 |
| 3 | PROGRAM MENU | 11 |
| 3.1 | Run Time Program | 11 |
| 3.2 | Dosing Program | 12 |
| 3.2.1 | Proportional Quantity | 13 |
| 3.2.2 | Proportional Time | 13 |
| 3.2.3 | Time | 14 |
| 3.2.4 | Quantity | 15 |
| 3.2.4.1 | Example of Dosing by Quantity (Spread) | 17 |
| 3.2.4.2 | Example of Controlled EC/pH Based on Proportional Quantity | 17 |
| 3.2.5 | EC Pre-Control | 18 |
| 3.3 | Irrigation Program | 19 |
| 3.3.1 | Setting Valve Sequence | 21 |
| 3.3.2 | Adjusting the Water Quantity Based on Weather Conditions | 24 |
| 3.3.3 | Configuring the Irrigation Calendar | 25 |
| 3.4 | Irrigation Based on External Conditions | 25 |
| 3.4.1 | Setting the Dry Contacts | 27 |
| 3.4.2 | Configuring the Analog Sensors | 28 |
| 3.5 | Irrigation Based on Radiation Sum | 30 |
| 3.6 | Irrigation Based on VPD Sum | 32 |
| 3.7 | Introduction to the Influence Program | 33 |
| 3.8 | Using the Influences | 33 |
| 3.8.1 | Setting the Influences | 33 |

| | | |
|----------|---|-----------|
| 3.8.2 | Radiation Influence on Target EC..... | 34 |
| 3.8.3 | Drainage Influence on Target Radiation Sum..... | 35 |
| 3.8.4 | Drain Influence on Minimum Time | 36 |
| 3.8.5 | Drainage EC Level Influence on Target EC | 37 |
| 3.8.6 | VPD Influence on Target EC..... | 39 |
| 3.8.7 | Temperature Influence on Target EC..... | 40 |
| 3.9 | Agitator..... | 41 |
| 3.10 | Selector..... | 42 |
| 3.11 | Filter Flushing..... | 42 |
| 3.12 | Cooling..... | 44 |
| 3.13 | Misting..... | 46 |
| 3.14 | Water Heating..... | 46 |
| 4 | MANUAL MENU..... | 47 |
| 4.1 | System Pause..... | 47 |
| 4.2 | Start/Stop Program..... | 48 |
| 4.3 | Start/Stop Valve..... | 48 |
| 4.4 | Manual Filter Flush..... | 49 |
| 5 | ALARM MENU..... | 51 |
| 5.1 | Reset..... | 51 |
| 5.2 | Alarm History..... | 52 |
| 5.3 | Alarm Definition..... | 52 |
| 5.4 | Alarm Setting..... | 54 |
| 5.5 | EC/pH Alarm Definition..... | 55 |
| 5.6 | EC/pH Alarm Setting..... | 55 |
| 5.7 | Radio System Alarm Definition..... | 55 |
| 5.8 | Radio System Alarm View..... | 56 |
| 5.9 | SMS Subscription..... | 56 |
| 6 | HISTORY MENU..... | 57 |
| 6.1 | Irrigation Log..... | 58 |
| 6.2 | RAD. & VPD SUM & DRAIN LOG..... | 59 |
| 6.3 | Uncompleted Irrigation..... | 59 |
| 6.4 | Uncompleted Programs..... | 60 |
| 6.5 | Daily Irrigation..... | 61 |
| 6.6 | Irrigation Accumulation..... | 62 |
| 6.7 | Aux Meter Accumulation..... | 62 |
| 6.8 | Accumulation Reset..... | 63 |
| 6.9 | Filters..... | 63 |
| 6.10 | Cooling..... | 64 |

| | | |
|------|------------|----|
| 6.11 | Sensor Log | 64 |
| 6.12 | Event Log | 65 |
| 6.13 | System Log | 65 |

| | | |
|---|----------|----|
| 7 | WARRANTY | 66 |
|---|----------|----|

1 Introduction

1.1 Disclaimer

Munters reserves the right to make alterations to specifications, quantities, dimensions etc. for production or other reasons, subsequent to publication. The information contained herein has been prepared by qualified experts within Munters. While we believe the information is accurate and complete, we make no warranty or representation for any particular purposes. The information is offered in good faith and with the understanding that any use of the units or accessories in breach of the directions and warnings in this document is at the sole discretion and risk of the user.

1.2 Introduction

Congratulations on your excellent choice of purchasing a Green Field Controller!

In order to realize the full benefit from this product it is important that it is installed, commissioned and operated correctly. Before installation or using the fan, this manual should be studied carefully. It is also recommended that it is kept safely for future reference. The manual is intended as a reference for installation, commissioning and day-to-day operation of the Munters Controllers.

1.3 Notes

Date of release: July 2019a





Munters cannot guarantee to inform users about the changes or to distribute new manuals to them.

All rights reserved. No part of this manual may be reproduced in any manner whatsoever without the expressed written permission of Munters. The contents of this manual are subject to change without notice.

2 General Information



- Keyboard
- Hot Screens
- Main Menu Icons
- Introduction to Irrigation Programs
- Operation Mode

2.1 Keyboard

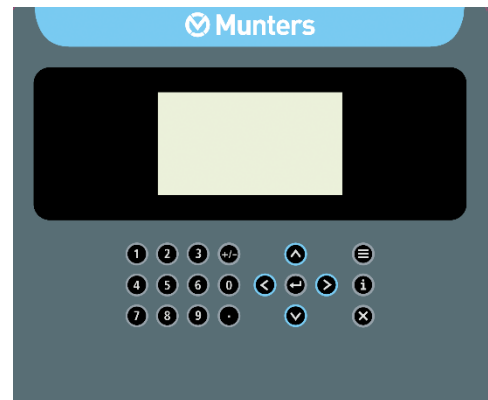
- **Numer keys:** Use these keys to enter values or quantities. In addition, they act as shortcuts to selections (see the following section).
- **+/- Key:** Toggles between positive and negative values and marks check boxes' option selection. In a History screen, use this key to toggle between quantities and time format.
- **Arrows:** Scroll up, down, left, and right to select menus.
-  **(MENU):** Press to get to the main menu; also acts as "ESC" and "Back" keys.
-  **(ENTER):** Enter menu, submenu, value, open window, and confirm a value or change.
-  **i:** Access Mode
-  **(DELETE):** Erases s typing mistake.



2.2 Hot Screens

Press  from the Main Menu to see Read-Only overview running processes. Press  again to return to the Main Menu.

There are 10 Hot Screens/Keys:

- **0:** Hot Key- Icon of active actions/processes
- **1:** Main Screen/System Status
- **2:** Irrigation Process
- **3:** Irrigation Program Status
- **4:** Water, EC/pH, Dosing

- 5: Filter Flushing Status
- 6: Temperature & Humidity measurement
- 7: Weather Station measurement
- 8: System Pressure
- 9: Drain Status

2.3 Main Menu Icons

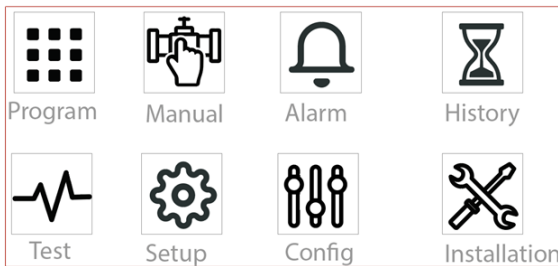

2.4 Introduction to Irrigation Programs

To set an irrigation program-regiment/strategy, the grower must select the necessary valves and set the Run Time and Dosing programs. The grower can define one or more programs for one or more valves. Refer to PROGRAM MENU, page 11 for detailed information on these programs.

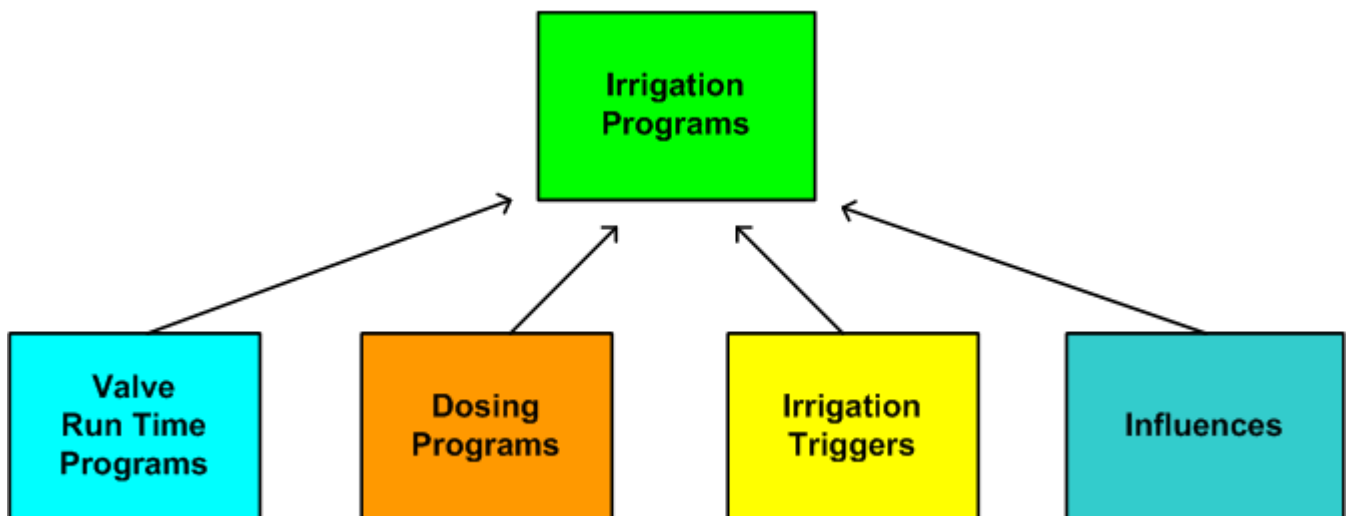

- **Run Time Programs**
 - Based on Time or Quantity
 - Set water before and after dosing process (fertilizer injection)
- **Dosing Programs (Fertilizer)**
 - Up to eight dosing channels per program
 - Each channel can be defined by:
 - Quantity
 - Proportional Quantity
 - Time
 - Proportional Time
- **Irrigation Timing Based on External Condition Programs**
 - Supports up to 15 programs

- Each program defines:
 - Time frame
 - Trigger
 - Trigger Type (for example one time only or multiple shots)

2.5 Operation Mode

There are three operation levels:

- **Read Only (restricted):** All the parameters and menus are visible, but cannot be modified
- **User (partially restricted):** Menus 1-6 are fully accessible and can be modified. Menus 7 and 8 can be viewed but not modified
- **Technician (unrestricted):** All menus are fully accessible (no restrictions)

To change the operation mode, press the **LOG IN** key

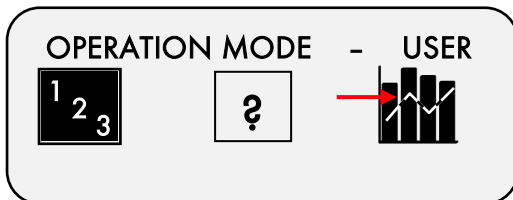

Click the **MODE** icon and insert the password

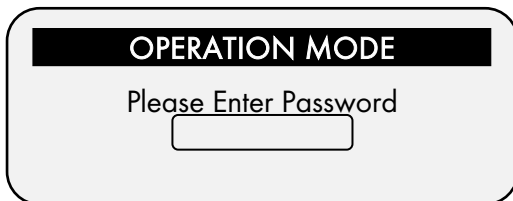

The controller recognizes the operation mode according to the password that is entered:

| MODE | PASSWORD |
|------------|----------|
| Read Only | 0000 |
| User | 9999 |
| Technician | 1948 |

Users can modify all menus except the Installation menus. Technicians can modify all menus.

If an incorrect password is entered, this screen appears.



The Operation mode can be configured to automatically return to the "Read-Only" mode after a certain amount of time.

*NOTE Refer to the **SYSTEM SETUP** section in the Installation Manual.*

| SYSTEM SETUP | | |
|-----------------------------|---|-----------|
| HISTORY | | |
| History Resolution | ▶ | 1 HOUR |
| WEATHER STATION | | |
| Controller Function | ▶ | LOCAL |
| OPERATION MODE | | |
| Automatic return to RO mode | ▶ | NO |
| Return period to RO mode | ▶ | 00:01 |
| COMMUNICATION | | |
| Controller Number | ▶ | 1 |
| Lower Port - Protocol | ▶ | GREEN NET |
| Lower Port - BaudRate | ▶ | 9600 |
| Upper Port - Protocol | ▶ | NONE |
| Upper Port - BaudRate | ▶ | 9600 |



- To perform a **cold start** or **firmware upgrade**, the controller must be in the “**Technician**” mode.
- If there is a power failure, the controller powers up with the last used mode.

NOTE The Return period parameter format is HH:MM. The minimum period is one minute.

3 Program Menu

The Program Menu is used to configure the irrigation programs. Configuration is a multistep process consisting of setting the following:

- Run Time Program (length of irrigation time or quantity of water to be distributed), page 11
- Dosing Program (fertilizer distribution program), page 12
- Irrigation (time frame and other parameters), page 19

In addition (or as alternative) to starting the irrigation based on time, irrigation can be set to begin based on:

- Irrigation Based on External Conditions, page 25
- Irrigation Based on Radiation Sum, page 30
- Irrigation Based on VPD Sum, page 32

Furthermore, you can adjust the irrigation process based on environmental factors such as the amount of radiation, the temperature, or other factors. Refer to Introduction to the Influence Program and Introduction to the Influence Program, page 33 for more details.

Lastly, use this menu to configure the following functions:

- Agitator, page 41
- Selector, page 42
- Filter Flushing, page 42
- Cooling, page 44
- Misting, page 46
- Water Heating, page 46

3.1 Run Time Program

For every irrigation program, define a Run Time program, which defines the how much water to distribute. Run Time can be based on either length of time or quantity of water. You can define up to 60 Run Time programs.

As an option, you can configure irrigation to run for a certain amount of time or quantity before dosing begins and/or after dosing ends. This process rinses the irrigation pipes of any residual matter.

To set the irrigation Run Time:

1. Go to Program > Water Run Time.
2. Select QTY or TIME.
3. Enter the water quantity/total run time.
4. Enter the Before and/or After quantity/time (optional).
5. Repeat as required for each program.



→ 2. Water Run Time



→ Qty. →

| WATER RUN TIME PROGRAM | | | | |
|------------------------|--------|--------|--------|-------|
| # | Method | Water | Before | After |
| 1 | QTY. | 10.000 | 0.000 | 0.000 |
| 2 | QTY. | 2.000 | 0.000 | 0.000 |
| 3 | QTY. | 0.000 | 0.000 | 0.000 |
| 4 | QTY. | 0.000 | 0.000 | 0.000 |
| 5 | QTY. | 0.000 | 0.000 | 0.000 |
| 6 | QTY. | 0.000 | 0.000 | 0.000 |
| 7 | QTY. | 0.000 | 0.000 | 0.000 |
| 8 | QTY. | 0.000 | 0.000 | 0.000 |
| 9 | QTY. | 0.000 | 0.000 | 0.000 |

→ Define Time →

| WATER RUN TIME PROGRAM | | | | |
|------------------------|--------|----------|----------|----------|
| # | Method | Water | Before | After |
| 1 | TIME | 00:15:00 | 00:00:00 | 00:00:00 |
| 2 | QTY. | 25.000 | 0.000 | 0.000 |
| 3 | QTY. | 0.000 | 0.000 | 0.000 |
| 4 | QTY. | 0.000 | 0.000 | 0.000 |
| 5 | QTY. | 0.000 | 0.000 | 0.000 |
| 6 | QTY. | 0.000 | 0.000 | 0.000 |
| 7 | QTY. | 0.000 | 0.000 | 0.000 |
| 8 | QTY. | 0.000 | 0.000 | 0.000 |
| 9 | QTY. | 0.000 | 0.000 | 0.000 |

→ ○ Define value for "before" and "after" time program

| WATER RUN TIME PROGRAM | | | | |
|------------------------|--------|----------|----------|----------|
| # | Method | Water | Before | After |
| 1 | TIME | 00:15:00 | 00:02:00 | 00:01:00 |
| 2 | QTY. | 25.000 | 5.000 | 5.000 |
| 3 | QTY. | 0.000 | 0.000 | 0.000 |
| 4 | QTY. | 0.000 | 0.000 | 0.000 |
| 5 | QTY. | 0.000 | 0.000 | 0.000 |
| 6 | QTY. | 0.000 | 0.000 | 0.000 |
| 7 | QTY. | 0.000 | 0.000 | 0.000 |
| 8 | QTY. | 0.000 | 0.000 | 0.000 |
| 9 | QTY. | 0.000 | 0.000 | 0.000 |
| 10 | QTY. | 0.000 | 0.000 | 0.000 |

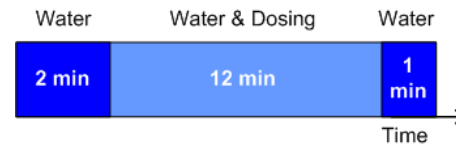

NOTE Whatever figure you enter in Before/After is deducted from the total run time/quantity. For example if the run time is 15 minutes, a Before time of two minutes and After time of one minute, then the net dosing time is 12 minutes.

3.2 Dosing Program

For every irrigation program, define a Dosing Program that defines the quantity of fertilizer per channel and its delivery method. You can define up to 10 Dosing Programs.

NOTE If there is more than one fertilizer tank for the selected dosing channel, refer to Selector, page 42.



→ 3. Dosing



| DOSING PROGRAM | | | |
|------------------------------|------|-------|-----|
| Program: 1 | | | |
| INJECTION PER DOSING CHANNEL | | | |
| 1 | 2 | 3 | --- |
| EC | EC | ACID | --- |
| 5.00 | 5.00 | 5.00 | --- |
| EC Dosing Method | | P.QTY | |
| PH Dosing Method | | P.QTY | |

Dosing can be according to one of the following:

- Proportional quantity
- Proportional time
- Quantity
- Time

3.2.1 PROPORTIONAL QUANTITY

Proportional Quantity is the quantity of fertilizer distributed per quantity of water. The proportion can be one of the following:

- Liters per cube of water
- Gallons per 1000 gallons of water

| DOSING PROGRAM | | | |
|------------------------------|---------|------|-----|
| Program: 1 | | | |
| INJECTION PER DOSING CHANNEL | | | |
| 1 | 2 | 3 | --- |
| EC | EC | ACID | --- |
| 5:00 | 6:00 | | --- |
| EC Dosing Meth | P. TIME | ME | |
| PH Dosing Meth | TIME | TY | |
| | QTY. | | |

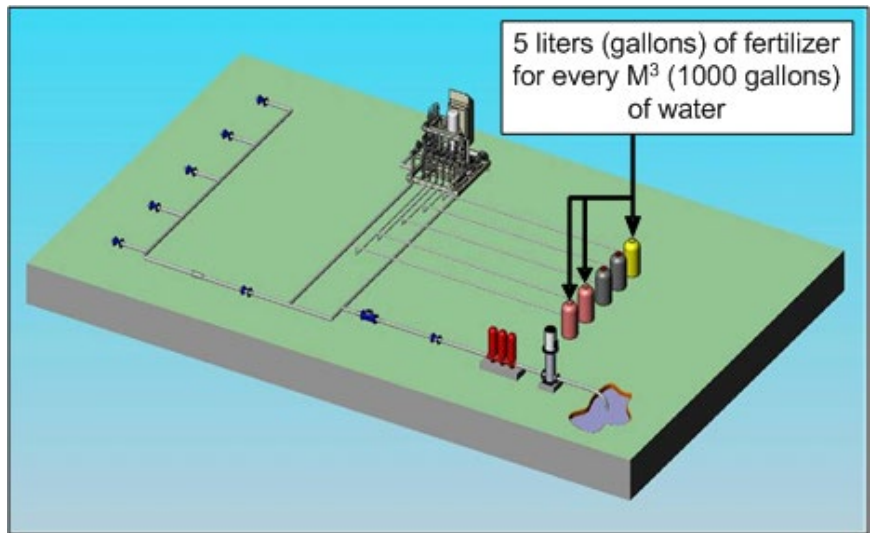

3.2.2 PROPORTIONAL TIME

Proportional Time takes the required dosing time and spreads out each dose over the irrigation program in one of two manners:

- Open/close pulses per channel
- Continual flow controlled by analog output

NOTE Refer to the Installation Manual for more details on configuring the method.

The diagram below shows how each the fertilizer is distributed over the total run time;

| DOSING PROGRAM | | | |
|------------------------------|---------|------|-----|
| Program: 1 | | | |
| INJECTION PER DOSING CHANNEL | | | |
| 1 | 2 | 3 | --- |
| EC | EC | ACID | --- |
| 00:10 | 00: | | --- |
| EC Dosing Meth | P. QTY | ME | |
| PH Dosing Meth | P. TIME | TY | |
| | TIME | | |
| | QTY. | | |

- A dose (P) is injected during irrigation according to the calculated schedule.

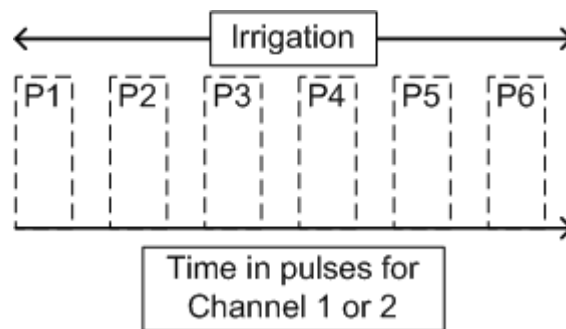

- The valve remains open during dosing, with the opening percentage determined by the quantity and dosing time.

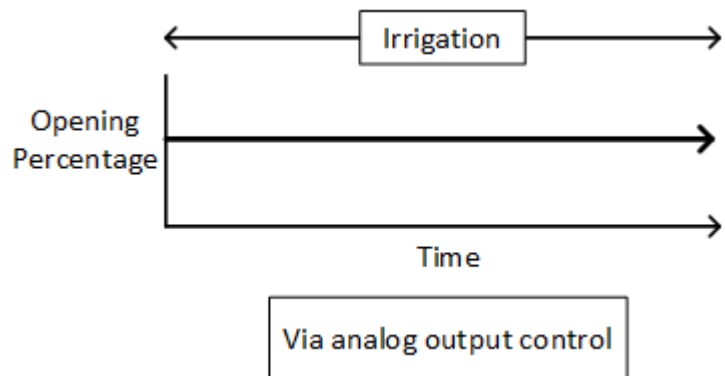

3.2.3 TIME

When using the Time delivery method, fertilizer is injected once, for the length of time defined in this screen.

| DOSING PROGRAM | | | |
|------------------------------|---------|------|-----|
| Program: 1 | | | |
| INJECTION PER DOSING CHANNEL | | | |
| 1 | 2 | 3 | --- |
| EC | EC | ACID | --- |
| 00:10 | 00: | | --- |
| EC Dosing Meth | P. QTY | ME | |
| PH Dosing Meth | P. TIME | TY | |
| | TIME | | |
| | QTY. | | |

| DOSING PROGRAM | | | |
|------------------------------|-------|-------|---|
| Program: 1 | | | |
| INJECTION PER DOSING CHANNEL | | | |
| 1 | 2 | 3 | - |
| EC | EC | ACID | - |
| 00:15 | 00:10 | 00:05 | - |
| | | | - |
| | | | - |
| | | | - |
| | | | - |
| EC Dosing Method | | TIME | |
| PH Dosing Method | | TIME | |

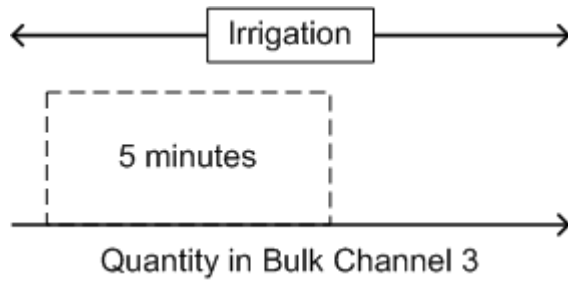

Example: In Channel 3, P1 = 5 minutes.
(one pulse)

3.2.4 QUANTITY

The Quantity method injects a fixed amount of fertilizer in the irrigation water. When using the Quantity method, there are two options:

- **Option A:** Bulk (similar to Time method). In this option, fertilizer is injected once, with the quantity defined in this screen.

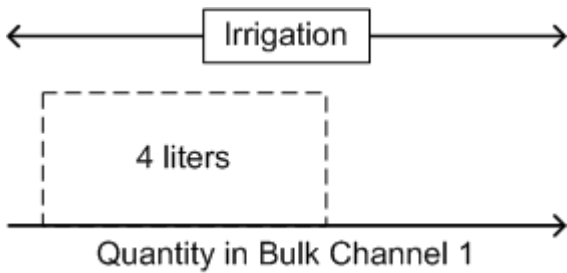

Example: Channel 1, P1 = four liters in one pulse

- **Option B:** Spread (according to dosing configuration set by a technician). Option B is similar to Proportional Time. In this method, fertilizer is spread out by quantity over the irrigation run time.

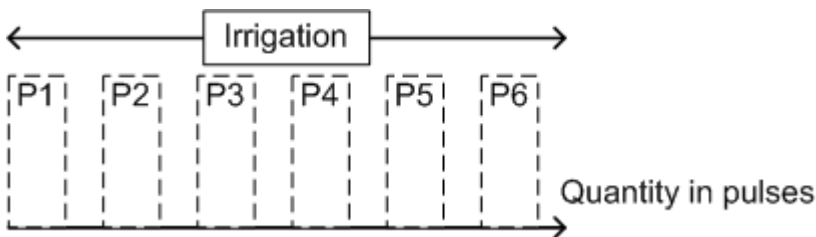

Example: Channel 1 = P1 + P2 + P3... + Pn = 4 liters

NOTE The example below shows liters; in the USA use gallons.



Qty.

| DOSING PROGRAM | | | |
|------------------------------|------|---------|-----|
| Program: 1 | | | |
| INJECTION PER DOSING CHANNEL | | | |
| 1 | 2 | 3 | --- |
| EC | EC | ACID | --- |
| 00:10 | 00: | P. TIME | --- |
| EC Dosing Meth | TIME | ME | |
| PH Dosing Meth | QTY. | TY | |

| DOSING PROGRAM | | | |
|------------------------------|------|------|-----|
| Program: 1 | | | |
| INJECTION PER DOSING CHANNEL | | | |
| 1 | 2 | 3 | --- |
| EC | EC | ACID | --- |
| 4.00 | 5.00 | 2.00 | --- |
| EC Dosing Method | QTY. | | |
| PH Dosing Method | QTY. | | |

When installing the Green Field Controller, the installation technician selects the required option. The user defines the quantity in the above screen.



Main Menu



7. Dosing Configuration



| DOSING CONFIGURATION | |
|----------------------------------|--------|
| EC Control | YES |
| Ph Control | YES |
| EC Alarms | YES |
| pH Alarms | YES |
| Minimum On Time (sec) | 0.8 |
| Minimum Off Time (sec) | 0.8 |
| EC Coarse Tuning | 5 |
| EC Fine Tuning | 5 |
| pH Coarse Tuning | 5 |
| pH Fine Tuning | 5 |
| Control Cycle EC | 4 |
| Control Cycle pH | 4 |
| EC/pH Averaging (0-Low, 20-High) | 3 |
| Dosing Boost Off Delay (mm:ss) | 00:02 |
| Dosing by QTY. Method | SPREAD |

Define according to Bulk or Spread

| DOSING PROGRAM | | | |
|------------------------------|------|------|-----|
| Program: 1 | | | |
| INJECTION PER DOSING CHANNEL | | | |
| 1 | 2 | 3 | --- |
| EC | EC | ACID | --- |
| 4.00 | 5.00 | 2.00 | --- |
| EC Dosing Method | QTY. | | |
| PH Dosing Method | QTY. | | |



Back in Dosing Program menu, define Injection per Dosing Channel.

3.2.4.1 Example of Dosing by Quantity (Spread)

Using Quantity (Spread) is normally done in an open field. The following is an example of a Quantity (Spread) configuration.

| DOSING PROGRAM | | | |
|------------------------------|--------|--------|-----|
| Program: 1 | | | |
| INJECTION PER DOSING CHANNEL | | | |
| 1 | 2 | 3 | --- |
| PASSIV | PASSIV | ACID | --- |
| 4.00 | 5.00 | 2.00 | --- |
| Target PH | | 5.50 | |
| Passive Method | | QTY. | |
| PH Dosing Method | | P.QTY. | |

Irrigation

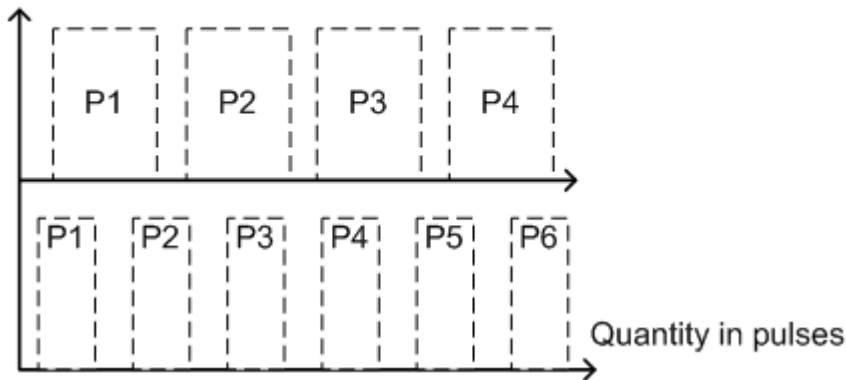

Ch. 1 ⇒ Spread Qty. = 4 liters

Ch. 2 ⇒ Spread Qty. = 5 liters

3.2.4.2 Example of Controlled EC/pH Based on Proportional Quantity

The following is an example of how to configure the controller so that the pH is maintained at a certain level.

| DOSING PROGRAM | | | |
|------------------------------|------|-------|-----|
| Program: 1 | | | |
| INJECTION PER DOSING CHANNEL | | | |
| 1 | 2 | 3 | --- |
| EC | EC | ACID | --- |
| 5.00 | 5.00 | 5.00 | --- |
| Target EC | | 1.50 | |
| Target PH | | 5.50 | |
| EC Dosing Method | | P.QTY | |
| PH Dosing Method | | P.QTY | |

Define dosing program: Nutrient amount and desired EC/pH levels

**Channel 3 (Acid channel): pH is controlled at 5.50. To keep pH levels on target, the Pulse width (meaning the quantity in each pulse) fluctuates according to controller calculations.

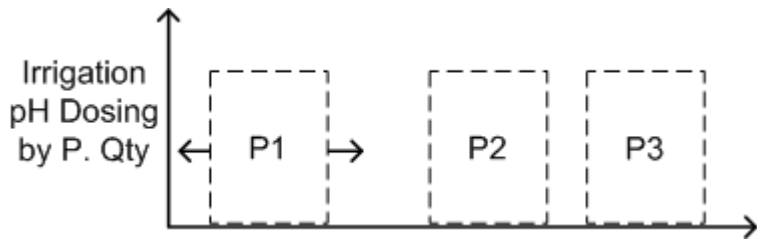

3 liter \Leftrightarrow 1m³
 pH Target = 5.5

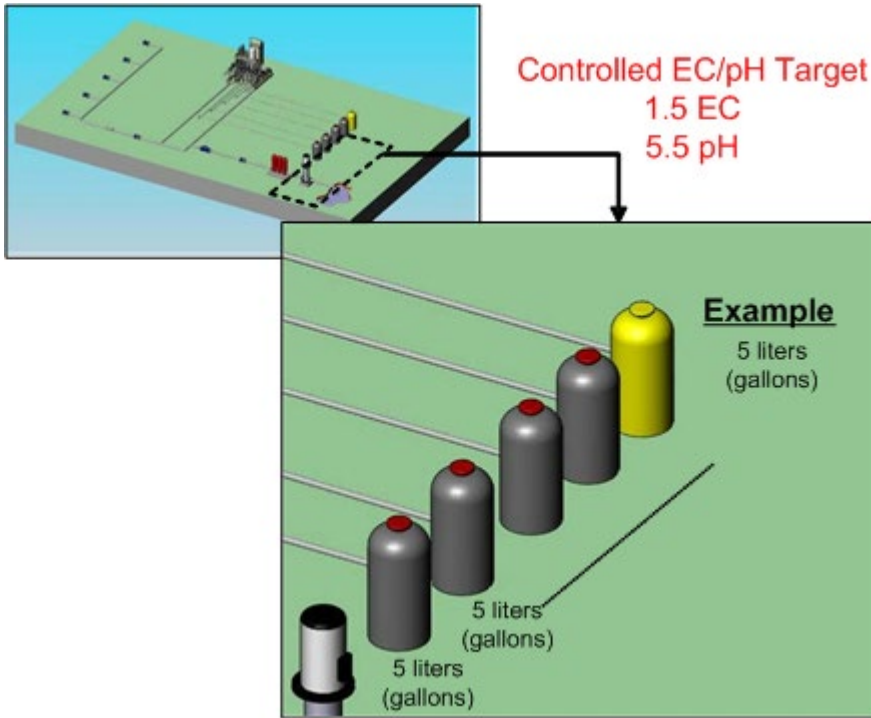

3.2.5 EC PRE-CONTROL

Use this option in hydraulic pre-control systems in greenhouses. When collecting excess water from drains, the grower can set an EC target before water goes through an irrigation system. This method reuses excess fertilizer and water, recycling them for a second irrigation run.

NOTE An EC Pre-Control valve relay must be defined by a technician at installation.



EC Pre-Control **ON** (this enables the control)

| DOSING PROGRAM | | | |
|-------------------------------------|------|-----------------|-----|
| Program: | 1 | EC Pre-Control: | ON |
| | | | OFF |
| INJECTION PER DOSING CHANNEL | | | |
| 1 | 2 | 3 | --- |
| EC | EC | ACID | --- |
| 2.00 | 5.00 | 3.00 | --- |
| Target EC | | 1.50 | |
| Target PH | | 5.50 | |
| EC Dosing Method | | P.QTY | |
| PH Dosing Method | | P.QTY | |

| DOSING PROGRAM | | | |
|------------------------------|------|-----------------|-----|
| Program: | 1 | EC Pre-Control: | ON |
| INJECTION PER DOSING CHANNEL | | | |
| 1 | 2 | 3 | --- |
| EC | EC | ACID | --- |
| 2.00 | 5.00 | 3.00 | --- |
| Target EC | | 1.50 | |
| Target PH | | 5.50 | |
| Target EC Pre-Control | | ----- | |
| EC Dosing Method | | P.QTY | |
| PH Dosing Method | | P.QTY | |



Define pre-controlled EC target

| DOSING PROGRAM | | | |
|------------------------------|------|-----------------|-----|
| Program: | 1 | EC Pre-Control: | ON |
| INJECTION PER DOSING CHANNEL | | | |
| 1 | 2 | 3 | --- |
| EC | EC | ACID | --- |
| 2.00 | 5.00 | 3.00 | --- |
| Target EC | | 1.50 | |
| Target PH | | 5.50 | |
| Target EC Pre-Control | | 0.80 | |
| EC Dosing Method | | P.QTY | |
| PH Dosing Method | | P.QTY | |

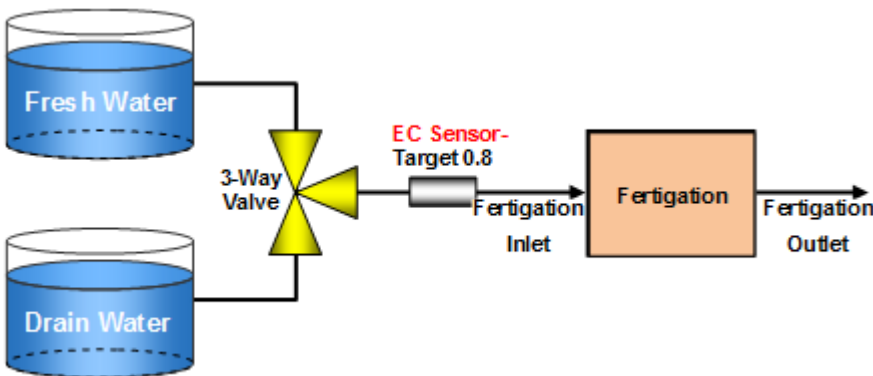

3.3 Irrigation Program

In the Irrigation Program screen, complete the irrigation setup.



1. Program



1. Irrigation



Select program



In this screen define the following:

- **Start time:** This parameter defines the irrigation program time period. Each period begins at the defined time and runs until the next defined time. Define up to six periods for each irrigation program. For example:
 - If you enter one time, the time period is 24 hours, starting from the time entered.
 - If you enter two times, the first period goes from first time defined until the second time. The second period then starts and continues until the first time. For example in the screen

below, the first period starts at 8:00 and continues until 10:00. The second period begins at 10:00 and continues until 8:00 (the next day).

- **Clock Start:** This parameter defines the number of irrigation cycles within each time period. In the example below, there are two cycles between 8:00 – 10:00 and three cycles from 10:00 – 8:00.
- **Min. Time:** The minimal amount of time between cycle starts

| | | | |
|---------------------------|------------------|------------------------|-----------|
| DATE : 19-Apr-07 | | TIME : 16:12:32 | |
| IRRIGATION PROGRAM | | | |
| Program: 4 | Priority: | Const. | 0% |
| | -- | | |
| Start Time | 08:00 | 10:00 | |
| Clock Start | 2 | 3 | |
| Min. Time | 01:00 | 01:00 | |
| Valve # | 001 | | |
| Run Time # | 1 | | |
| Dosing Prog | 1 | | |
| Day: 01/01 | 1 | | |
| Dose/Water | D | | |

- **Valve #:** Select that irrigation valve(s) open(s) (refer to Setting Valve Sequence, page 21).
- **Run Time #:** Select the required Run Time Program (refer to Run Time Program, page 11).
- **Dosing Prog:** Select the required Dosing Program (refer to Dosing Program, page 12).
- **Day:** Type the current day/number of days in cycle (refer to Configuring the Irrigation Calendar, page 25).
- **Dose/Water:** For each day define the irrigation regime (refer to Configuring the Irrigation Calendar, page 25).
- **Irrigation Adjustments:** Along with irrigation programs based on time, Green Field enables adjusting or running irrigation based on the following:
 - Adjusting the Water Quantity Based on Weather Conditions, page 24
 - Irrigation Based on External Conditions, page 25
 - Irrigation Based on Radiation Sum, page 30
 - Irrigation Based on VPD Sum, page 32
 - Introduction to the Influence Program, page 33

3.3.1 SETTING VALVE SEQUENCE

The following section provides examples on how to set the valves' sequence.

Example 1: Cycling Irrigation Program for One Valve

In the following example, Irrigation Program 4 begins running at 8:00 AM. There are two cycles, with one hour in between each cycle. Irrigation is from one valve. Run Time program 1 and Dosing Program 1 are used.

| DATE : 19-Apr-07 | | TIME : 16:12:32 | |
|--------------------|--------------|-----------------|----|
| IRRIGATION PROGRAM | | | |
| Program: 4 | Priority: -- | Const. | 0% |
| Start Time | 08:00 | | |
| Clock Start | 2 | | |
| Min. Time | 01:00 | | |
| Valve # | 001 | | |
| Run Time # | 1 | | |
| Dosing Prog | 1 | | |
| Day: 01/01 | 1 | | |
| Dose/Water | D | | |

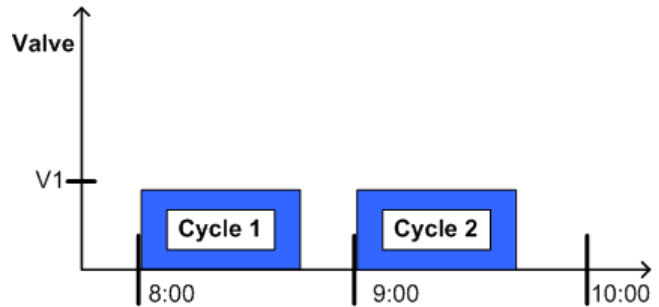

Valve 1 runs two cycles, one hour between start times on Run Time & Dosing Program 1

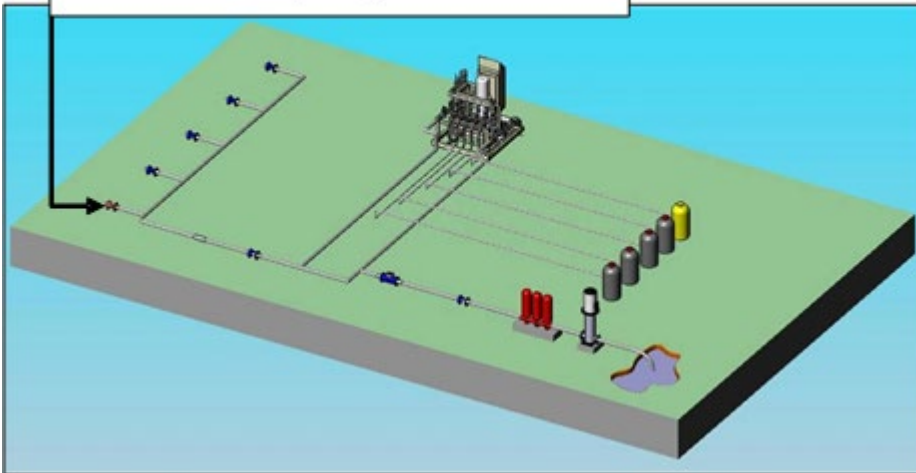

Example 2: Cycling Irrigation Program for Group of Two Valves

In this example, two valves operate simultaneously (valves operating together is called a group). All other specifications are the same as those found in Example 1.

NOTE Valves in the same group must have the same run time.

| | | | |
|---------------------------|-----------|-----------------|----|
| DATE : 19-Apr-07 | | TIME : 16:12:32 | |
| IRRIGATION PROGRAM | | | |
| Program: 4 | Priority: | Const. | 0% |
| | -- | | |
| Start Time | 08:00 | | |
| Clock Start | 2 | | |
| Min. Time | 01:00 | | |
| Valve # | 001 + 002 | | |
| Run Time # | 1 | 1 | |
| Dosing Prog | 1 | 1 | |
| Day: 01/01 | 1 | | |
| Dose/Water | D | | |

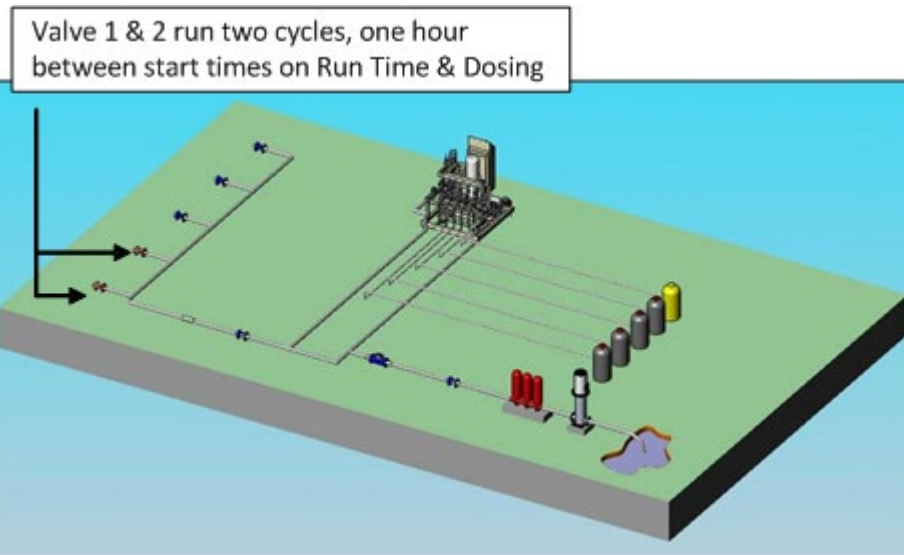
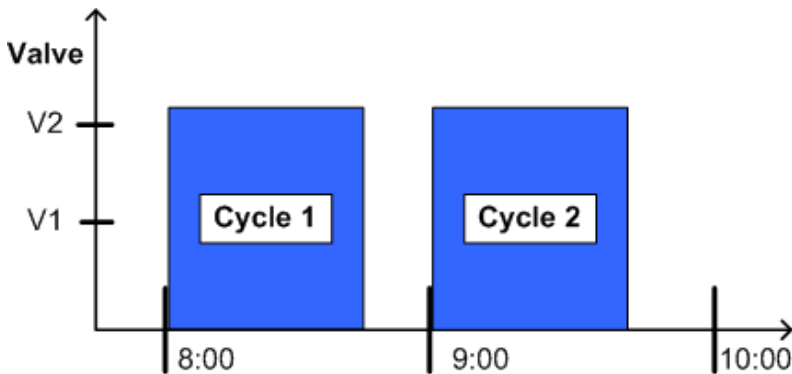

Example 3: Irrigation Program for a Group and Individual Valve

In this example, Valves 1 and 2 are designated as a group. Valve 3 is designated as an individual valve. There are different/interchangeable delays (multiple start time) dividing the day into periods.

The first cycle's (C1) run time begins at 8:00 (Valve 1 and 2). Valve 3 begins operating at its run time. In this example, Valve 3 begins operating after Valve 1 and 2 finishes. This process is repeated once (C2), with a break of one hour between cycle start times.

Cycle 3 (C3) begins at 10:30. In this cycle, there is a 30 minute break between cycles (C4). The process continues as shown in **the graph below**.

| | | | |
|--|------------------|---------------|--------------|
| DATE : 19-Apr-07 TIME : 16:12:32 | | | |
| IRRIGATION PROGRAM | | | |
| Program: 4 | Priority: | Const. | 0% |
| | -- | | |
| Start Time | 08:00 | 10:30 | 12:30 |
| Clock Start | 2 | 2 | 2 |
| Min. Time | 01:00 | 00:30 | 01:00 |
| Valve # | 001 + 002 | 003 | |
| Run Time # | 1 | 1 | 2 |
| Dosing Prog | 1 | 1 | 2 |
| Day: 01/03 | 1 | 2 | 3 |
| Dose/Water | D | W | D |

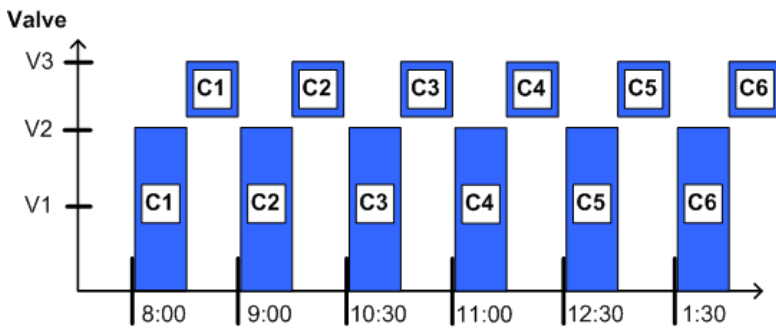

Valve 1 & 2 run six cycles simultaneously on Run Time & Dosing Program 1, Valve 3 runs after Valves 1 & 2 on Run Time & Dosing Program 2, with different/interchangeable start times.

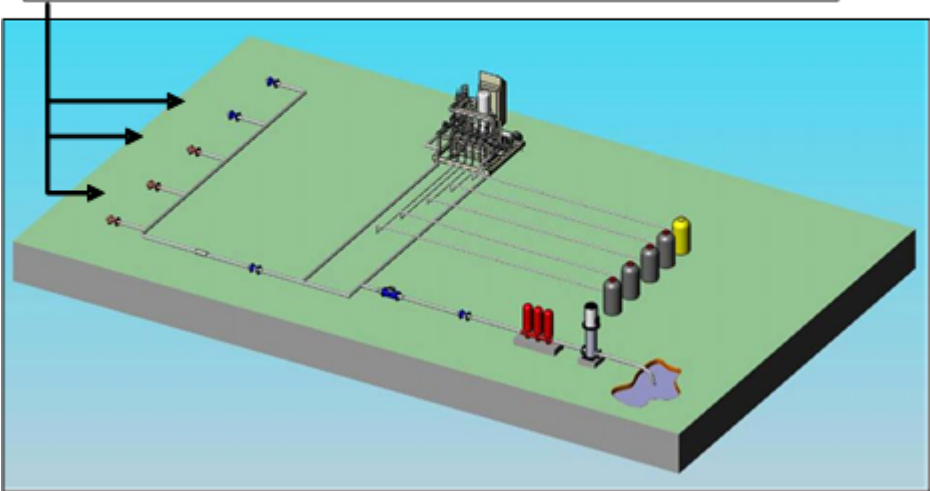

3.3.2 ADJUSTING THE WATER QUANTITY BASED ON WEATHER CONDITIONS

The Green Field Controller enables you to manually increase or decrease the quantity of water on any given day. Depending on the weather conditions, you can change the quantity of water emitted from valves without changing the program.

Example 4: Increasing Irrigation

In this example, **water** is supplemented by 20% to compensate for an increase in heat. If the regular run time is 10 minutes, the actual run time will be 12 minutes. All other specifications are the same as those found in Example 3.

NOTE The change to the programs affects both Valves 1 and 2, and Valve 3.

NOTE Dosing is **not** affected when using this function, only the quantity of water.

There are two options:

- **Daily:** Program adjustment is for one day only. Regular program resumes the following day.
- **Const:** Program adjustment continues until changed.

| DATE : 19-Apr-07 | | TIME : 16:12:32 | |
|--------------------|-------------|-----------------|-----------|
| IRRIGATION PROGRAM | | | |
| Program: | 4 | Priority: | Daily 20% |
| | | | -- |
| Start Time | 08:00 10:30 | | |
| Clock Start | 2 2 | | |
| Min. Time | 01:00 00:30 | | |
| Valve # | 001+002 003 | | |
| Run Time # | 1 | 1 | 2 |
| Dosing Prog | 1 | 1 | 2 |
| Day: 01/01 | 1 | 2 | 3 |
| Dose/Water | D | W | - |



Example 5: Decreasing Irrigation

In this example, irrigation is decreased by 10% to compensate for a decrease in heat. If the regular run time is 10 minutes, the actual run time is nine minutes.

| DATE : 19-Apr-07 | | TIME : 16:12:32 | |
|--------------------|-------------|-----------------|------------|
| IRRIGATION PROGRAM | | | |
| Program: | 4 | Priority: | Daily -10% |
| | | | -- |
| Start Time | 08:00 10:30 | | |
| Clock Start | 2 2 | | |
| Min. Time | 01:00 00:30 | | |
| Valve # | 001+002 003 | | |
| Run Time # | 1 | 1 | 2 |
| Dosing Prog | 1 | 1 | 2 |
| Day: 01/01 | 1 | | |
| Dose/Water | D | | - |



3.3.3 CONFIGURING THE IRRIGATION CALENDAR

Green Field enables scheduling irrigation programs by:

- Daily calendar
- Irrigation by dosing or water

When setting up a schedule, configure the following:

- **Day: X/Y**
 - X represents the first day that the cycle begins. For example, if you want to define the first day of the cycle as day 4, define X as 4.
 - Y represents the length of the cycle. If the length is 7 days, define Y as 7. You can schedule up to 14 days.
- **Dose/Water:** For each day, define what the regime type for each day:
 - Dose: Water and dosing
 - Water: Water only
 - None: No irrigation

| | | | | | | | |
|---------------------------|--------------------|------------------------|------------|---|---|---|---|
| DATE : 19-Apr-07 | | TIME : 16:12:32 | | | | | |
| IRRIGATION PROGRAM | | | | | | | |
| Program: | Priority: | Daily | 20% | | | | |
| 4 | -- | | | | | | |
| Start Time | 08:00 | 10:30 | | | | | |
| Clock Start | 2 | 2 | | | | | |
| Min. Time | 01:00 | 00:30 | | | | | |
| Valve # | 001+002 003 | | | | | | |
| Run Time # | 1 | 1 | 2 | | | | |
| Dosing Prog | 1 | 1 | 2 | | | | |
| Day: 04/07 | 1 | 2 | 3 | 4 | 5 | 6 | 7 |
| Dose/Water | D | - | D | W | D | - | D |

| | | | | | | |
|---|---|---|---|---|---|---|
| 1 | 2 | 3 | 4 | 5 | 6 | 7 |
| X | | X | X | X | | X |
| | | | | | | |
| | | | | | | |
| | | | | | | |

Select the daily calendar

AND Irrigation by dosing or water

| | | | | | | | |
|---------------------------|---------------------|------------------------|------------|---|---|---|---|
| DATE : 19-Apr-07 | | TIME : 16:12:32 | | | | | |
| IRRIGATION PROGRAM | | | | | | | |
| Program: 4 | Priority: -- | Daily | 20% | | | | |
| Start Time | 08:00 | 10:30 | | | | | |
| Clock Start | 2 | 2 | | | | | |
| Min. Time | 01:00 | 00:30 | | | | | |
| Valve # | 001 | 003 | | | | | |
| Run Time # | 1 | 1 | | | | | |
| Dosing Prog | 1 | None | | | | | |
| Day: 04/07 | 1 | 2 | 3 | 4 | 5 | 6 | 7 |
| Dose/Water | D | - | D | W | D | - | D |

In this example, the seven day cycle begins on the fourth day (04/07). On the fourth day, the irrigation is water only (no dosing).

| | | | | | | |
|---|---|---|---|---|---|---|
| 1 | 2 | 3 | 4 | 5 | 6 | 7 |
| D | - | D | W | D | - | D |
| | | | | | | |
| | | | | | | |
| | | | | | | |

3.4 Irrigation Based on External Conditions

Irrigation can be controlled by input from dry contact or analog sensor triggers.

- If the Irrigation Program is active, these programs can only function after the Irrigation Program is completed.

- If the Irrigation Program is inactive, these programs can function during the defined time frame.
- In both cases, irrigation begins only when external conditions meet the user-defined requirements.

Irrigation programs can be controlled via dry contact input or analog sensors from peripheral equipment (for example, filling a water tank according to level float switch). When using dry contacts or analog sensors, set the following:

- Time frame that the program can operation
- Which trigger input starts and stops irrigation
- The trigger type:
 - One Shot: Irrigation runs once
 - Multi Shot: Irrigation continues to run until a stop signal is received
 - Only If On: Used when there is one switch only. Irrigation continues as long as switch remains on

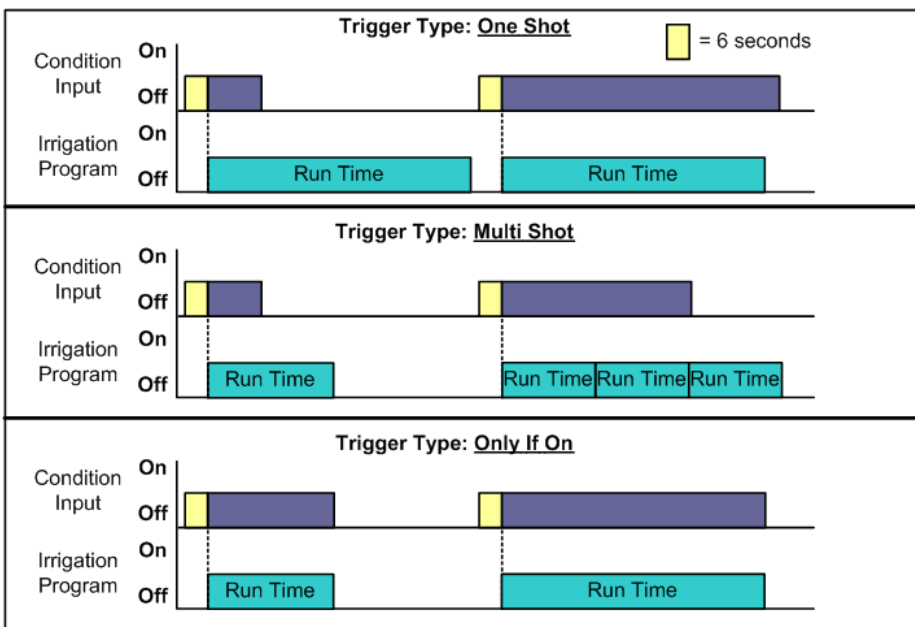

Green Field supports up to 15 extension programs defining which trigger initiates irrigation. In each program, the start and stop trigger must be the same type (meaning both must be dry contact or analog sensor). To configure an irrigation program triggered by external condition:



1. Program



1. Irrigation



| DATE : 1-May-07 TIME : 10:12:09 | | | |
|--------------------------------------|--------------|---------|---------|
| IRRIGATION PROGRAM | | | |
| Program: 1 | Priority: -- | Cond. 1 | |
| Start Time | 07:00 | 08:00 | 10:00 |
| Clock Start | 1 | -- | 6: |
| Contact | ON | 300 | 0 |
| Min. Time | --:-- | 00:30 | Cond. |
| Max. Time | --:-- | --:-- | Rad Sum |
| Valve # | 001 | | |
| Run Time # | 1 | | |
| Dosing Prog | 1 | | |

For Next Screen Press The DOWN Arrow

The following sections detail how to set up the dry contact and analog sensor triggers.

3.4.1 SETTING THE DRY CONTACTS

The following section details how to set dry contact to control irrigation.





4. Ext. Condition

This is the time frame in which the condition (if true) can operate.

| EXTERNAL CONDITION PROGRAM | | | |
|----------------------------|------------|----------|-----------------|
| # | From hh:mm | To hh:mm | Start Dry Cont. |
| 1 | 07:00 | 18:00 | Dry Con 1 |
| 2 | --:-- | --:-- | <NONE> |
| 3 | --:-- | --:-- | <NONE> |
| 4 | --:-- | --:-- | <NONE> |
| 5 | --:-- | --:-- | <NONE> |
| 6 | --:-- | --:-- | <NONE> |
| 7 | --:-- | --:-- | <NONE> |
| 8 | --:-- | --:-- | <NONE> |
| 9 | --:-- | --:-- | <NONE> |

Select trigger type



| EXTERNAL CONDITION PROGRAM | | | |
|----------------------------|-----------------|--------------|------------|
| # | Start Dry Cont. | Trigger Type | Stop Dry |
| 1 | Dry Con 1 | One Shot | One Shot |
| 2 | <NONE> | One Shot | Multi Shot |
| 3 | <NONE> | One Shot | <NONE> |
| 4 | <NONE> | One Shot | <NONE> |
| 5 | <NONE> | One Shot | <NONE> |
| 6 | <NONE> | One Shot | <NONE> |
| 7 | <NONE> | One Shot | <NONE> |
| 8 | <NONE> | One Shot | <NONE> |

Select dry contact to start and stop external condition program.



| EXTERNAL CONDITION PROGRAM | | | |
|----------------------------|-----------------|--------------|----------------|
| # | Start Dry Cont. | Trigger Type | Stop Dry Cont. |
| 1 | Dry Con 1 | One Shot | Dry Con 2 |
| 2 | <NONE> | Shot | <NONE> |
| 3 | <NONE> | One Shot | <NONE> |
| 4 | <NONE> | Shot | <NONE> |
| 5 | <NONE> | One Shot | <NONE> |
| 6 | <NONE> | Shot | <NONE> |
| 7 | <NONE> | One Shot | <NONE> |
| 8 | <NONE> | Shot | <NONE> |
| 9 | <NONE> | One Shot | <NONE> |

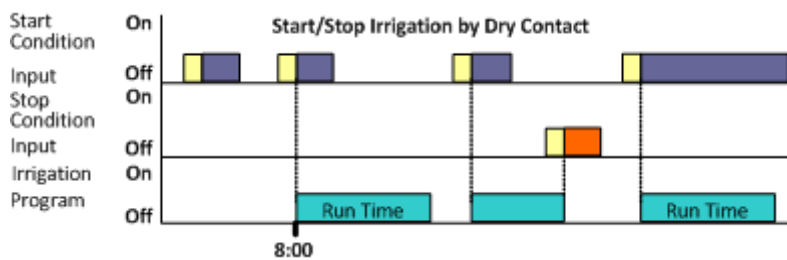

Example of Tank Filling:

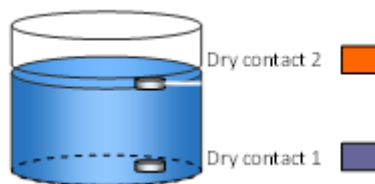

Water Tank with Floats

3.4.2 CONFIGURING THE ANALOG SENSORS

The following section details how to configure analog sensors to control irrigation.

NOTE In general, a technician performs steps 1 and 2 during installation. The user only begins from step 3.

1. In *Setup > Analog Conversion Table*:

- a. Select the sensor type. Each sensor has default values assigned to it.
 - o ECH20: 0 - 60
 - o General Sensor: 0.2 - 10
- b. If required, edit the values.

| ANALOG CONVERSION TABLE | | | |
|-------------------------|-------------|-----------|-----------|
| Num. | Sensor Type | Min Value | Max Value |
| 1 | ←-> | ←-> | ←-> |
| 2 | ←-> | ←-> | ←-> |
| 3 | ←-> | ←-> | ←-> |
| 4 | ←-> | ←-> | ←-> |

| ANALOG CONVERSION TABLE | | | |
|-------------------------|-------------|-----------|-----------|
| Num. | Sensor Type | Min Value | Max Value |
| 1 | | 7 | 45 |
| 2 | <NONE> | 7 | 45 |
| 3 | ECh20 | 7 | 45 |
| 4 | Temperature | 7 | 45 |
| | Gen. Sensor | | |

2. In *Test > Analog Sensor*, view the actual sensor values.

| ANALOG SENSOR | | |
|---------------|-------------|-------|
| No. | Type | Value |
| 1 | Gen. Sensor | 11 |
| 2 | Gen. Sensor | 22 |
| 3 | ECh20 | 33 |
| 4 | ECh20 | 7 |
| 5 | ECh20 | 3 |
| 6 | Temperature | 25 |
| 7 | Temperature | 32 |
| 8 | <NONE> | 51 |
| 9 | <NONE> | 21 |
| 10 | <NONE> | 21 |

3. In *Program > Ext Condition*, configure the External Condition Program for the analog sensors.

a. Enter the beginning and ending time for each program

| EXTERNAL CONDITION PROGRAM | | | |
|----------------------------|------------|----------|---------------------|
| # | From hh:mm | To hh:mm | Start An. Dry Cont. |
| 1 | 10:00 | 12:00 | Ana. Sen 1 |
| 2 | 11:00 | 12:00 | Dry Con 1 |
| 3 | 12:00 | 13:00 | Dry Con 1 |
| 4 | --:-- | --:-- | <NONE> |
| 5 | --:-- | --:-- | <NONE> |
| 6 | --:-- | --:-- | <NONE> |
| 7 | --:-- | --:-- | <NONE> |
| 8 | --:-- | --:-- | <NONE> |

b. Under Start An. Dry Cont., define the input type.

| EXTERNAL CONDITION PROGRAM | | | |
|----------------------------|------------|----------|---------------------|
| # | From hh:mm | To hh:mm | Start An. Dry Cont. |
| 1 | | 12:00 | Ana. Sen 1 |
| 2 | Ana. Sen 1 | 12:00 | Dry Con 1 |
| 3 | Ana. Sen 2 | 13:00 | Dry Con 1 |
| 4 | Ana. Sen 3 | --:-- | <NONE> |
| 5 | Ana. Sen 4 | --:-- | <NONE> |
| 6 | Ana. Sen 5 | --:-- | <NONE> |
| 7 | Ana. Sen 6 | --:-- | <NONE> |
| 8 | | --:-- | <NONE> |

c. Define The Trigger Type.

| EXTERNAL CONDITION PROGRAM | | | |
|----------------------------|--------------|-------------------|----------------|
| # | Trigger Type | Stop An Dry Cont. | Oper. to Start |
| 1 | Multi Shot | Ana. Sen 2 | --- |
| 2 | Multi Shot | Dry Con 2 | One Shot |
| 3 | One Shot | Dry Con 14 | Multi Shot |
| 4 | One Shot | <NONE> | Only If On |
| 5 | One Shot | <NONE> | --- |
| 6 | One Shot | <NONE> | --- |
| 7 | One Shot | <NONE> | --- |
| 8 | One Shot | <NONE> | --- |

d. Under Stop An. Dry Con., define the input type.

| EXTERNAL CONDITION PROGRAM | | | |
|----------------------------|--------------|-------------------|----------------|
| # | Trigger Type | Stop An Dry Cont. | Oper. to Start |
| 1 | | Ana. Sen 2 | --- |
| 2 | Ana. Sen 1 | Dry Con 2 | --- |
| 3 | Ana. Sen 2 | Dry Con 14 | --- |
| 4 | Ana. Sen 3 | <NONE> | --- |
| 5 | Ana. Sen 4 | <NONE> | --- |
| 6 | Ana. Sen 5 | <NONE> | --- |
| 7 | Ana. Sen 6 | <NONE> | --- |
| 8 | | <NONE> | --- |

e. Under Oper. to Start, choose the required symbol.

| EXTERNAL CONDITION PROGRAM | | | |
|----------------------------|-------------------|----------------|-------------|
| # | Stop An Dry Cont. | Oper. to Start | Start Value |
| 1 | Ana. Sen 2 | > | |
| 2 | Dry Con 2 | --- | --- |
| 3 | Dry Con 14 | --- | < |
| 4 | <NONE> | --- | <= |
| 5 | <NONE> | --- | = |
| 6 | <NONE> | --- | > |
| 7 | <NONE> | --- | >= |
| 8 | <NONE> | --- | |

f. Under Oper. To Stop, choose the required symbol.

| EXTERNAL CONDITION PROGRAM | | | |
|----------------------------|----------------|-------------|---------------|
| # | Oper. to Start | Start Value | Oper. to Stop |
| 1 | | 25 | = |
| 2 | --- | --- | --- |
| 3 | < | --- | --- |
| 4 | <= | --- | --- |
| 5 | = | --- | --- |
| 6 | > | --- | --- |
| 7 | >= | --- | --- |
| 8 | --- | --- | --- |

g. Under Start Value, enter the required value to start the analog sensor. Under Stop Value, entered the required value to stop the analog sensor.

| EXTERNAL CONDITION PROGRAM | | | |
|----------------------------|-------------|---------------|------------|
| # | Start Value | Oper. to Stop | Stop Value |
| 1 | 25 | = | 20 |
| 2 | --- | --- | --- |
| 3 | --- | --- | --- |
| 4 | --- | --- | --- |
| 5 | --- | --- | --- |
| 6 | --- | --- | --- |
| 7 | --- | --- | --- |
| 8 | --- | --- | --- |

In the examples given above, irrigation has been set to start when the analog input is greater than 25 and irrigation stops when the input is 20.

Oper. to Start and Oper. to Stop require a logical operation. The following table defines these symbols:

| Symbol | Definition |
|--------|--|
| – | No operation |
| <, <= | The analog sensor function value is less than/less than or equal to the start/stop value. |
| = | The analog sensor function value is equal to the start/stop value. There is a $\pm 1\%$ allowable deviation. |
| >, >= | The analog sensor function value is greater than/greater than or equal to the start/stop value. |

3.5 Irrigation Based on Radiation Sum

Green Field enables setting an irrigation trigger based on a radiation sum limit (joul/cm² = energy). When using this option, set the following:

- **Start Time:** Start Time is when the unit begins measuring radiation levels to implement the irrigation program.
- **Clock Start:** Number of cycles. 0 (zero) means that this program is disabled. 1 (one) means that this program runs one time after time-based irrigation is completed. 2 (two) means that the program runs twice, and so on.
- **Radiation Sum Limit:** This parameter determines the minimal amount of accumulated radiation required for irrigation to start.
- **Minimum Time:** When irrigation begins, Green Field erases the current radiation sum and restarts the count. Minimum time is the minimal amount of time between irrigation starts, even if the radiation sum has reached its limit.
- **Maximum Time:** This parameter determines the maximum amount of time between irrigation starts, even if the sum limit has not been reached.



1. Program

→ 1. Irrigation →

| DATE : 1-May-07 | | TIME : 10:12:09 | |
|--------------------|---------------------|-----------------|--------------|
| IRRIGATION PROGRAM | | | |
| Program: 1 | Priority: -- | Rad Sum | |
| Start Time | 07:00 | 08:00 | 10:00 |
| Clock Start | 1 | -- | 6:00 |
| Rad Sum Li. | 100 | 300 | 0 |
| Min. Time | --:-- | 00:30 | --:-- |
| Max. Time | --:30 | --:-- | --:-- |
| Valve # | 001 | | |
| Run Time # | 1 | | |
| Dosing Prog | 1 | | |

For Next Screen Press The DOWN Arrow

| DATE : 1-May-07 | | TIME : 10:12:09 | |
|--------------------|---------------------|-----------------|---------------------|
| IRRIGATION PROGRAM | | | |
| Program: 1 | Priority: -- | Rad Sum | |
| Start Time | 07:00 | 08:00 | 10:00- 16:00 |
| Clock Start | 1 | -- | -- |
| Rad Sum Li. | 100 | 300 | 150 |
| Min. Time | --:-- | 00:30 | 00:20 |
| Max. Time | --:30 | 01:00 | 01:00 |
| Valve # | 001 | | |
| Run Time # | 1 | | |
| Dosing Prog | 1 | | |

For Next Screen Press The DOWN Arrow

In the example below, between 8:00 – 10:00, the Radiation Sum Limit is 300; between 10:00 – 16:00 the limit is 150. Since during the afternoon hours there is a greater amount of sunlight, the user lowered the limit to ensure that they receive sufficient amounts of irrigation.

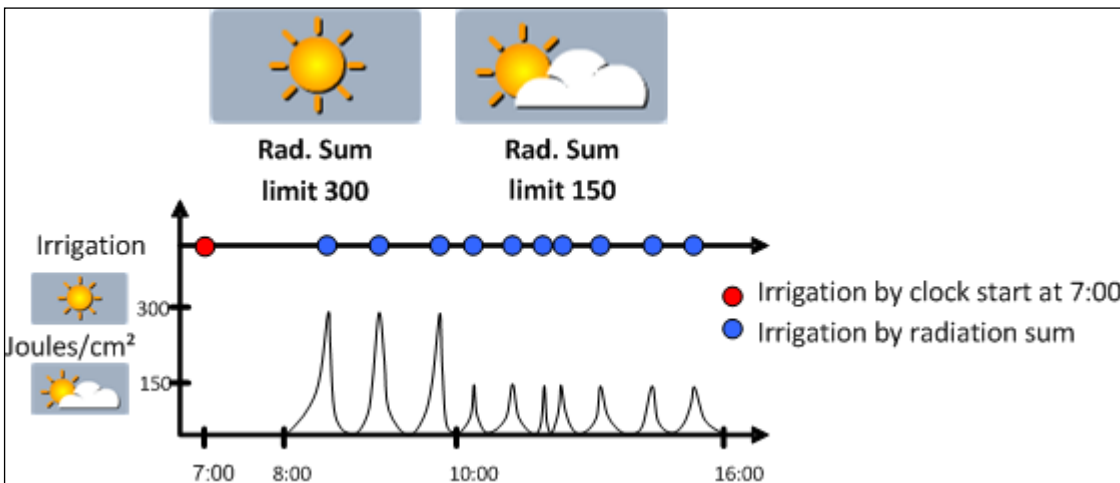

3.6 Irrigation Based on VPD Sum

Green Field enables setting an irrigation trigger based on Vapor Pressure Deficit (kPa • min). The Vapor Pressure Deficit (VPD) is a measurement which incorporates both the relative humidity (RH) and the temperature. When the VPD is high, that means that the RH is low or the temperature is high. Irrigation begins when the VPD reaches the user-defined limit.



1. Program



| DATE : 1-May-07 | | TIME : 10:12:09 | |
|--------------------|--------------|-----------------|-------|
| IRRIGATION PROGRAM | | | |
| Program: 1 | Priority: -- | VPD | Daily |
| Start Time | 07:00 | 08:00 | 10:00 |
| Clock Start | 1 | -- | -- |
| Rad Sum Li. | ---- | 30 | 150 |
| Min. Time | --:-- | 00:30 | 00:20 |
| Max. Time | --:-- | --:-- | --:-- |
| Valve # | 001 | | |
| Run Time # | 1 | | |
| Dosing Prog | 1 | | |

| DATE : 1-May-07 | | TIME : 10:12:09 | |
|--------------------------------------|--------------|-----------------|-------------|
| IRRIGATION PROGRAM | | | |
| Program: 1 | Priority: -- | VPD Sum | |
| Start Time | 07:00 | 08:00 | 10:00 16:00 |
| Clock Start | 1 | -- | -- |
| VPD Sum Li. | ---- | 30 | 15 |
| Min. Time | --:-- | 00:30 | 00:20 |
| Max. Time | --:-- | 01:00 | 01:00 |
| Valve # | 001 | | |
| Run Time # | 1 | | |
| Dosing Prog | 1 | | |
| For Next Screen Press The DOWN Arrow | | | |

Irrigation based on VPD Sum can take place only during the VPD time frame. Refer to 6.1 SETUP > TIME & DATE to define the start and end time for VPD Sum. Normally, this parameter is defined during installation.

- **Start Time:** Start Time is when the unit begins measuring and calculating VPD levels to implement the irrigation program.
- **Clock Start:** Number of cycles. 0 (zero) means that this program is disabled. 1 (one) means that this program runs one time after time-based irrigation is completed. 2 (two) means that the program runs twice, and so on.
- **VPD Sum Limit:** This parameter determines the minimal (accumulated) VPD required for irrigation to start.
- **Minimum Time:** When irrigation begins, Green Field erases the current VPD sum and restarts the count. Minimum time is the minimal amount of time between irrigation starts, even if the radiation sum has reached its limit.
- **Maximum Time:** This parameter determines the maximum amount of time between irrigation starts, even if the VPD limit has not been reached.

3.7 Introduction to the Influence Program

Green Field enables adjusting irrigation settings according the following factors (labeled “Influences” on the screen):

- Solar radiation
- Amount of drainage
- Amount of fertilizer present in the drainage
- VPD
- Temperature

These Influences can adjust the following irrigation settings:

- EC
- Radiation Sum (RadS)
- Minimum Rest Time (MinT)

For example, a grower may want to increase the EC based on the Solar Radiation. Alternatively, he may want to decrease the MinT based on the drainage.

3.8 Using the Influences

- Set an Influence to increase or decrease the setting.
- Changes to the setting are in percentages (for example, a 10% increase in the EC level).
- Several Influences adjust the EC setting. The final adjustment amount is based on the sum total of the different Influences.
- You enter up to three points for each Influence setting. Green Field automatically calculates the curve based on these points.
- You can program up to 15 different programs (corresponding to the 15 irrigation programs)
- After configuring an Influence, you must enable it (under ACTIVE/SOURCE).

3.8.1 SETTING THE INFLUENCES

1. Go to *Install > Device Layout*.
2. Define relays as dosing channels, as required.
3. Go to *Program > Irrigation*.
4. Using the arrow keys, scroll down to Screen 2. The following screen appears.

| DATE: 2 -Feb-12 | | TIME 12:52-08 | |
|--------------------|-------------------------------------|---------------|----|
| IRRIGATION PROGRAM | | | |
| Program: 1 | Priority: -- | Const. | 0% |
| INFLUENCE | TABLE | ACTIVE/SOURCE | |
| Radia./EC | <input checked="" type="checkbox"/> | NO | |
| Drain/RadS | <input checked="" type="checkbox"/> | NO | |
| Drain/MinT | <input checked="" type="checkbox"/> | NO | |
| EC Drain/EC | <input checked="" type="checkbox"/> | NO | |
| VPD/EC | <input checked="" type="checkbox"/> | NO | |
| Temp/EC | <input checked="" type="checkbox"/> | NO | |

Screen 2 of 2 – In order to view the

5. Set the required Influences to YES.

The following sections detail each Influence.

NOTE The following sections include examples. These examples are not meant to be actual numbers used in practice; they simply illustrate the operating principles. Consult with your local extension agent for actual specifications.

3.8.2 RADIATION INFLUENCE ON TARGET EC

This function enables adjusting the EC based on solar radiation. Solar radiation increases the greenhouse temperature. Adjust the EC according to your crops' requirements.

To set the Radiation Influence:

1. In *Installation > Analog Input*, define a sensor as EC.
2. In *Configuration > Dosing Channel Configuration*, set React to EC.
3. In *Configuration > Dosing Configuration > EC Control* to Yes.
4. In *Program > Irrigation*, select Radia./EC.
5. Define the Radiation set points (w/m2).
6. Define the EC change in percentages.
7. Set ACTIVE/SOURCE to Yes.
8. Press Menu and confirm changes.
9. In *Program > Dosing Program*, set:
 - a. the Target EC
 - b. EC Dosing Method to Qty

Example: As sunlight increases, a crop needs lower EC levels. The following screen illustrates increasing in the EC based on radiation. Since Green Field calculates the decrease in EC proportionally, there will be a 15% decrease when the radiation reaches 600 w/m2.

| DATE: 2 -Feb-12 | | TIME 12:52-08 | |
|---------------------------|-------------------------------------|----------------------|------------|
| IRRIGATION PROGRAM | | | |
| Program: 1 | Priority: -- | Const. 0% | |
| INFLUENCE | TABLE | ACTIVE/SOURCE | |
| Radia./EC | <input checked="" type="checkbox"/> | Radia. | EC |
| Drain/RadS | <input checked="" type="checkbox"/> | (w/m2) | (%) |
| Drain/MinT | <input checked="" type="checkbox"/> | 200 | 0 |
| EC Drain/EC | <input checked="" type="checkbox"/> | 400 | -10 |
| VPD/EC | <input checked="" type="checkbox"/> | 800 | -20 |
| Temp/EC | <input checked="" type="checkbox"/> | | |

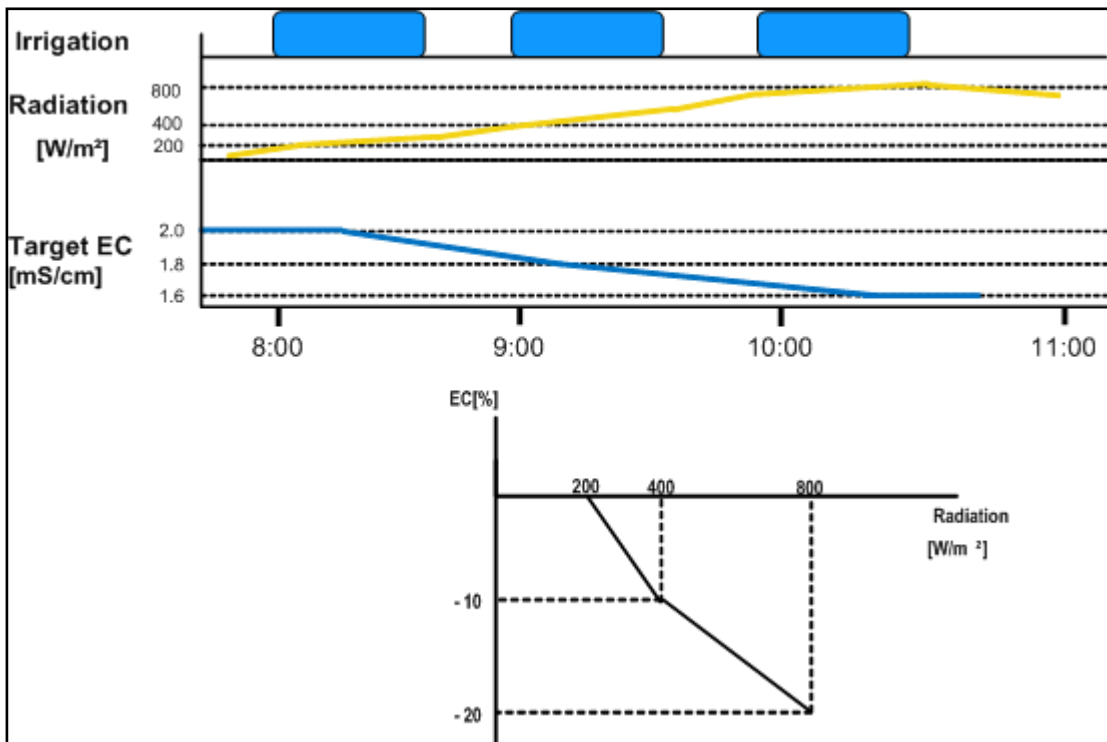

3.8.3 DRAINAGE INFLUENCE ON TARGET RADIATION SUM

Irrigation can be triggered by the Radiation Sum (Rad Sum). This Influence enables adjusting the Rad Sum based on the amount of drainage.

To set the Drainage Influence on Rad Sum:

1. In *Program > Irrigation*, set Contr. to Rad Sum.
2. In *Installation > Digital Input*, define which digital input is the drain meter.

NOTE The drainage must be defined correctly! You can check the drainage meter status using Hot key 9.

3. In *Configuration > Valve Configuration* define which valve number corresponds to which drainage meter.
4. In *Configuration > Drainage Configuration*, define the drainage meter's Ratio Liter/Pulse.
5. In *Program > Irrigation*, select Drain/RadS.
 - a. Define the Drainage percentage set points.
 - b. Define the RadS percentage set points.
6. Set ACTIVE/SOURCE to Yes.

7. Press  and confirm changes.

Example: A user set irrigation to be triggered by the radiation sum. As can be seen, the increases are not proportional.

DATE: 2 –Feb-12 TIME 12:52-08

| IRRIGATION PROGRAM | | | |
|--------------------|-------------------------------------|---------------|------|
| Program: 1 | Priority: -- | Const. | 0% |
| INFLUENCE | TABLE | ACTIVE/SOURCE | |
| Radia./EC | <input checked="" type="checkbox"/> | DRAIN% | RadS |
| Drain/RadS | <input checked="" type="checkbox"/> | (%) | (%) |
| Drain/MinT | <input checked="" type="checkbox"/> | 20 | -10 |
| EC Drain/EC | <input checked="" type="checkbox"/> | 30 | 10 |
| VPD/EC | <input checked="" type="checkbox"/> | 55 | 30 |
| Temp/EC | <input checked="" type="checkbox"/> | | |

Screen 2 of 2 – In order to view the

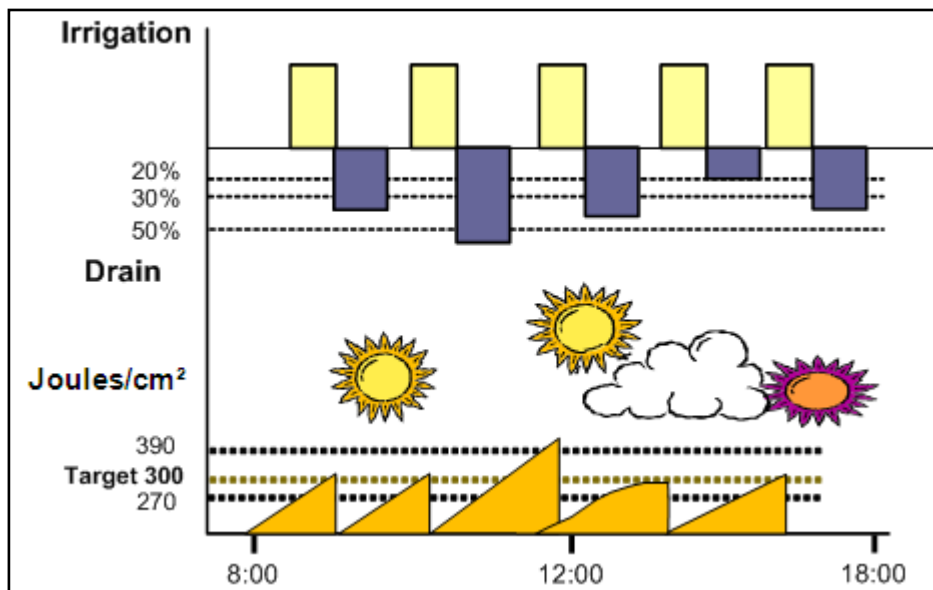

3.8.4 DRAIN INFLUENCE ON MINIMUM TIME

Minimum time defines the minimum break between irrigations. Even if the Rad/VPD sum limit / condition limit has been reached irrigation does not take place until this time has passed. This function enables adjusting the Minimum Time based on the drainage.

To set the Drainage Influence on the Minimum Time:

1. In *Installation > Digital Input*, define which digital input is the drain meter.

NOTE The drainage must be defined correctly! You can check the drainage meter status using Hot key 9.

2. In *Configuration > Valve Configuration* define which valve number corresponds to which drainage meter.
3. In *Configuration > Drainage Configuration*, define the drainage meter's Ratio Liter/Pulse.
4. In *Program > Irrigation*, select Drain/MinT.
 - a. Define the Drainage percentage set points.
 - b. Define the MinT percentage set points.
5. Set ACTIVE/SOURCE to Yes.

6. Press  and confirm changes.

Example: When drainage is low, a user wants to decrease the Minimum Time. He sets 20% drainage to a MinT of -25%. As drainage increases, the time between irrigation increases. In this scenario, if the MinT is set to 60 minutes, 40% drainage adjusts the time to 75 minutes.

| DATE: 2 -Feb-12 | | TIME 12:52-08 | |
|---------------------------|-------------------------------------|----------------------|-------------|
| IRRIGATION PROGRAM | | | |
| Program: 1 | Priority: -- | Const. | 0% |
| INFLUENCE | TABLE | ACTIVE/SOURCE | |
| Radia./EC | <input checked="" type="checkbox"/> | DRAIN% | MinT |
| Drain/RadS | <input checked="" type="checkbox"/> | (%) | (%) |
| Drain/MinT | <input checked="" type="checkbox"/> | 20 | -25 |
| EC Drain/EC | <input checked="" type="checkbox"/> | 40 | 25 |
| VPD/EC | <input checked="" type="checkbox"/> | | |
| Temp/EC | <input checked="" type="checkbox"/> | | |

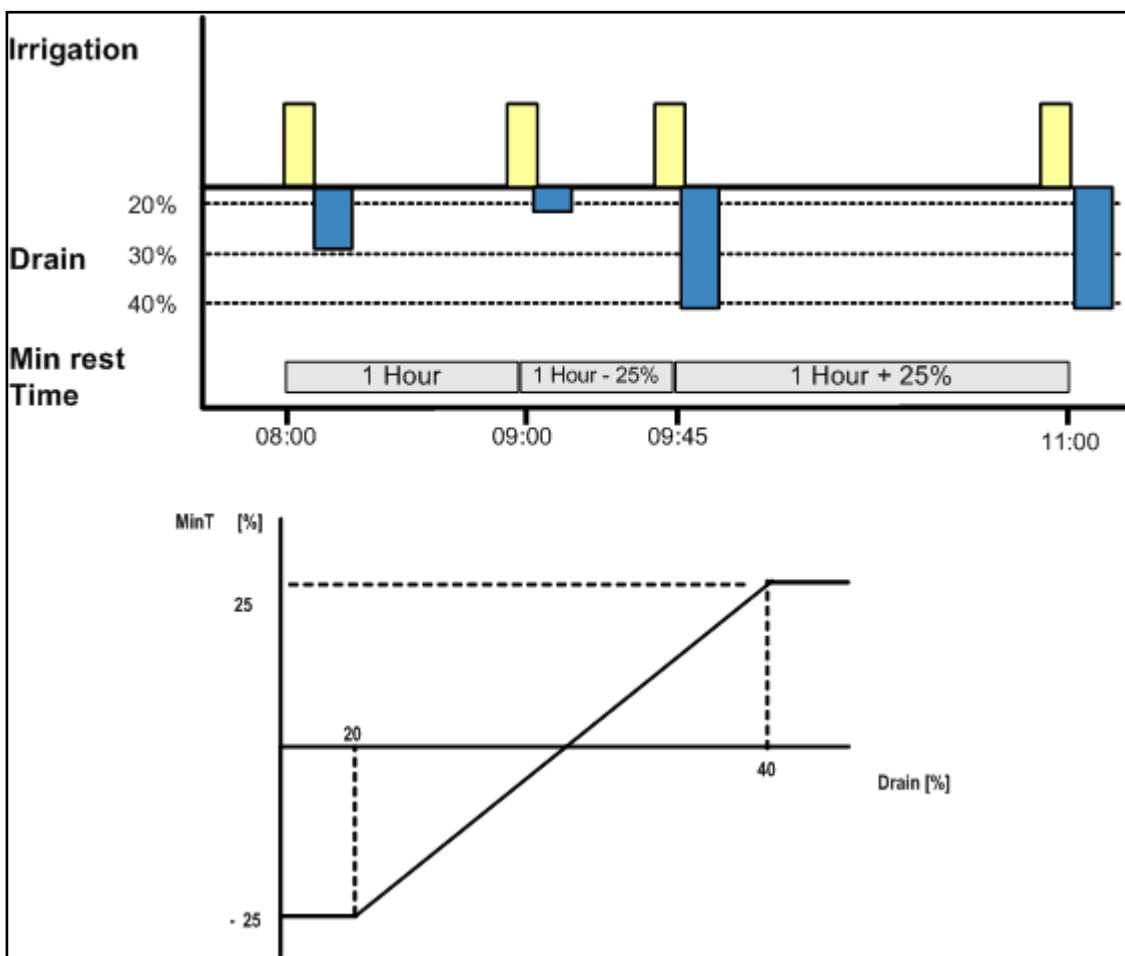

3.8.5 DRAINAGE EC LEVEL INFLUENCE ON TARGET EC

If you have installed an EC sensor in the drainage, you can adjust the Target EC level based on the drainage EC level. This can be used, for example, to lower the EC input if EC levels in the drainage are above specifications.

To set the EC Drainage Influence on the EC:

1. In *Installation > Analog Input*:
 - a. Define a sensor as EC.
 - b. Define a sensor as EC drain.

2. In *Installation > Digital*/Input define which digital input is the drain meter.

NOTE The drainage must be defined correctly! You can check the drainage meter status using Hot Key 9.

3. In *Configuration > Valve Configuration* define which valve number corresponds to which drainage meter.

4. In *Configuration > Dosing Channel Configuration* set React to EC.

5. In *Configuration > Dosing Configuration > EC Control* to Yes.

6. In *Configuration > Drainage Configuration*, define the drainage meter's Ratio Liter/Pulse.

7. In *Program > Irrigation*, select EC Drain/EC.

a. Define the EC Drain percentage set points.

b. Define the EC percentage set points.

8. Set ACTIVE/SOURCE to Yes.



9. Press  and confirm changes.

10. In *Program > Dosing Program* set the Target EC.

NOTE You can disable this function by disabling EC Control (*Configuration > Dosing Configuration*).

| DATE: 2 -Feb-12 | | TIME 12:52-08 | |
|--------------------|-------------------------------------|----------------------|-----|
| IRRIGATION PROGRAM | | | |
| Program: 1 | Priority: -- | Const. | 0% |
| INFLUENCE | TABLE | ACTIVE/SOURCE | |
| | | | |
| Radia./EC | <input checked="" type="checkbox"/> | EC Drain / EC | |
| Drain/RadS | <input checked="" type="checkbox"/> | mS/cm | (%) |
| Drain/MinT | <input checked="" type="checkbox"/> | 1 | 0 |
| EC Drain/EC | <input checked="" type="checkbox"/> | 2 | -10 |
| VPD/EC | <input checked="" type="checkbox"/> | 3 | -20 |
| Temp/EC | <input checked="" type="checkbox"/> | | |

Screen 2 of 2 – In order to view the

Example: A user wants to maintain an EC level of 1.5. To this end, he measures the drainage EC. When the drainage EC falls below 1.5, he increases the EC input. As it rises above 1.5 ms/cm, he decreases the input.

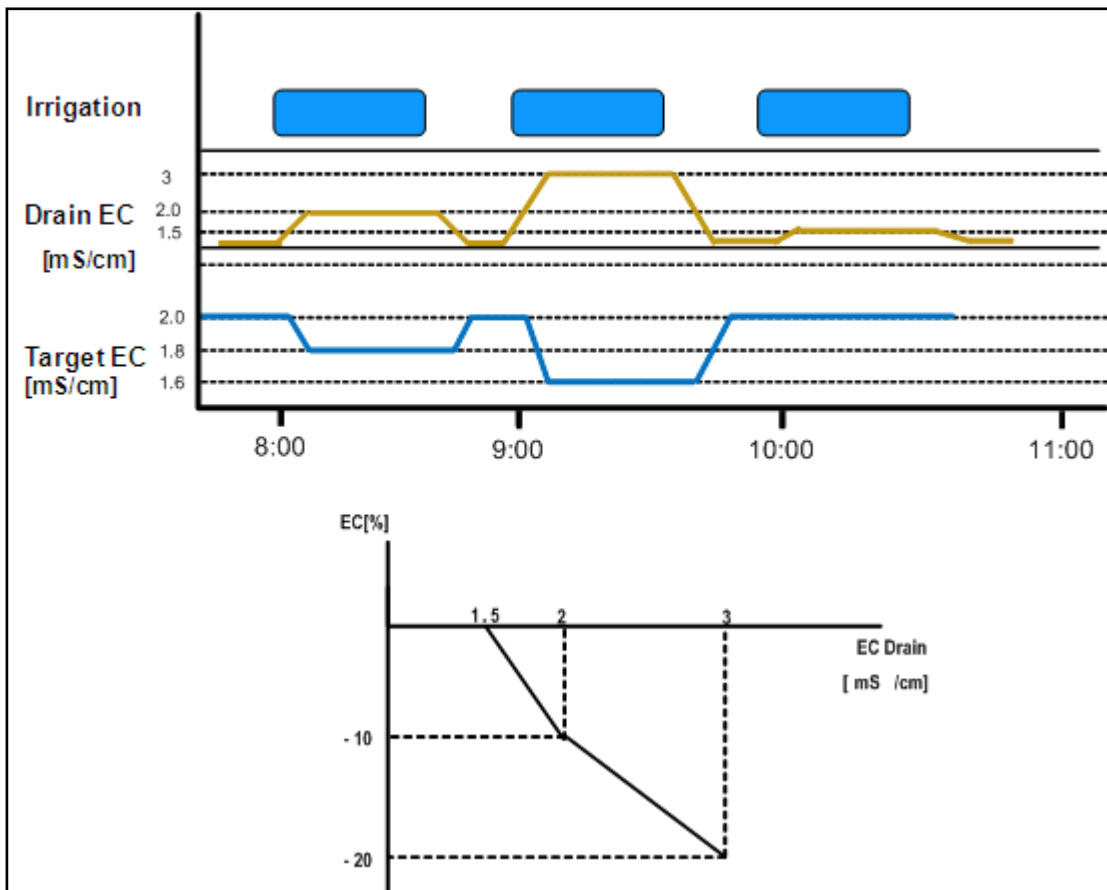

3.8.6 VPD INFLUENCE ON TARGET EC

You can adjust the EC based on the VPD Sum (air temperature and humidity). As the VPD rises or falls, the program can increase or decrease the EC level according to your requirements.

1. In *Installation > Analog Input* define:
 - a. a sensor as EC.
 - b. an air temperature sensor.
 - c. a humidity sensor.

NOTE You can verify the EC status using Hot Key Screen, the temperature and humidity sensors status using Hot Key Screen 6.

2. In *Setup > VPD Sensor Setup*, enable VPD Temperature and VPD Humidity sensors.
3. In *Configuration > Dosing Channel Configuration* set React to EC.
4. In *Configuration > Dosing Configuration > EC Control*, set EC Control to Yes.
5. In *Program > Irrigation*, select VPD/EC.
 - a. Define the VPD sum points.
 - b. Define the EC percentage set points.
6. Set ACTIVE/SOURCE to Yes.
7. In *Program > Dosing Program*:
 - a. Set the Target EC.
 - b. Set EC Dosing Method to Qty.

Example: A grower wants to lower the EC as the kPa decreases. He sets this screen to reduce the increase in EC to match the decreasing VPD levels.

DATE: 2 –Feb-12 TIME 12:52-08

| IRRIGATION PROGRAM | | | |
|--------------------|-------------------------------------|---------------|-----|
| Program: 1 | Priority: -- | Const. | 0% |
| INFLUENCE | TABLE | ACTIVE/SOURCE | |
| Radia./EC | <input checked="" type="checkbox"/> | VPD | EC |
| Drain/RadS | <input checked="" type="checkbox"/> | (kPa) | (%) |
| Drain/MinT | <input checked="" type="checkbox"/> | 15 | 7 |
| EC Drain/EC | <input checked="" type="checkbox"/> | 10 | 4 |
| VPD/EC | <input checked="" type="checkbox"/> | 5 | 2 |
| Temp/EC | <input checked="" type="checkbox"/> | | |

Screen 2 of 2 – In order to view the

3.8.7 TEMPERATURE INFLUENCE ON TARGET EC

You can adjust the EC based on the air temperature. As the temperature rises or falls, the program can increase or decrease the EC level according to your requirements.

1. In *Installation > Analog Input* define:

- a. a sensor as EC
- b. an air temperature sensor

NOTE You can verify the EC status using Hot Key Screen 4 and the temperature sensor status using Hot Key Screen 6.

2. In *Configuration > Dosing Channel Configuration* set React to EC.
3. In *Configuration > Dosing Configuration > EC Control*, set EC Control to Yes.
4. In *Program > Irrigation*, select Temp/EC.
 - a. Define the Temperature sum points.
 - b. Define the EC percentage set points.
5. Set ACTIVE/SOURCE, select the temperature sensor number.

DATE: 2 –Feb-12 TIME 12:52-08

| IRRIGATION PROGRAM | | | |
|--------------------|-------------------------------------|----------|----|
| Program: 1 | Priority: -- | NO | 0% |
| INFLUENCE | TABLE | OUT temp | |
| | | Temp 1 | |
| Radia./EC | <input checked="" type="checkbox"/> | Temp 2 | |
| Drain/RadS | <input checked="" type="checkbox"/> | Temp 3 | |
| Drain/MinT | <input checked="" type="checkbox"/> | Temp 4 | |
| EC Drain/EC | <input checked="" type="checkbox"/> | N/A | |
| VPD/EC | <input checked="" type="checkbox"/> | NO | |
| Temp/EC | <input checked="" type="checkbox"/> | NO | |

Screen 2 of 2 – In order to view the

6. In *Program > Dosing Program*:
 - a. set the Target EC.
 - b. set EC Dosing Method to Qty.

Example: A grower's flower crop requires higher EC levels when the temperature goes above room temperature 22° C). Using this screen, he can adjust the levels accordingly.

DATE: 2 -Feb-12 TIME 12:52-08

| IRRIGATION PROGRAM | | | |
|--------------------|-------------------------------------|---------------|-------|
| Program: 1 | Priority: -- | Const. 0% | |
| INFLUENCE | PRIORITY | ACTIVE/SOURCE | |
| Radia./EC | <input checked="" type="checkbox"/> | Temp | EC |
| Drain/RadS | <input checked="" type="checkbox"/> | (°C/F) | (%) |
| Drain/MinT | <input checked="" type="checkbox"/> | 25 | 2 |
| EC Drain/EC | <input checked="" type="checkbox"/> | 27 | 5 |
| VPD/EC | <input checked="" type="checkbox"/> | 30 | 7 |
| Temp/EC | <input checked="" type="checkbox"/> | | TEMP1 |

3.9 Agitator

Use this screen to operate fertilizer tanks equipped with mixing devices.



1. Program



5. Agitator



| AGITATOR | | |
|-------------------|-------------|--------------|
| | On mm:ss | Off mm:ss |
| Dosing Active | --:-- | --:-- |
| Dosing Not Active | --:-- | --:-- |
| Operation Mode | Parallel | |



Define On/Off time during dosing and when system is idle

| AGITATOR | | |
|-------------------|--|--------------|
| | On mm:ss | Off mm:ss |
| Dosing Active | 01:00 | 05:00 |
| Dosing Not Active | 05:00 | 60:00 |
| Operation Mode | Parallel | |
| | <input type="radio"/> Parallel <input type="radio"/> Serial | |



- Select **Parallel** to operate more than one agitator simultaneously
- Select **Serial** if not enough power to operate more than one agitator at a time



| AGITATOR | | |
|-------------------|-------------|--------------|
| | On mm:ss | Off mm:ss |
| Dosing Active | 01:00 | 05:00 |
| Dosing Not Active | 05:00 | 60:00 |
| Operation Mode | Serial | |

3.10 Selector

Use this screen to operate more than one fertilizer tank (containing different fertilizers) attached to a single dosing channel. The program enables taking fertilizer from different tanks (according to the dosing program).

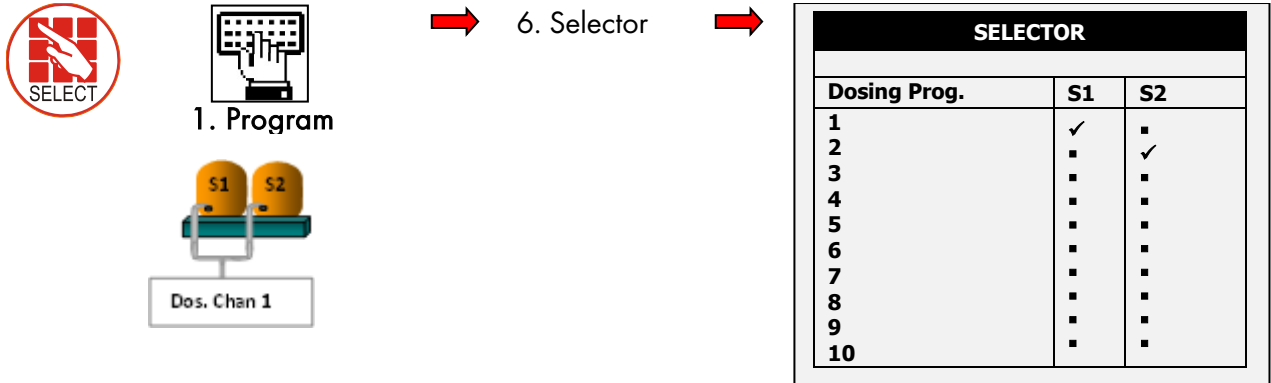

3.11 Filter Flushing

Use this screen to program filter flushing during irrigation.

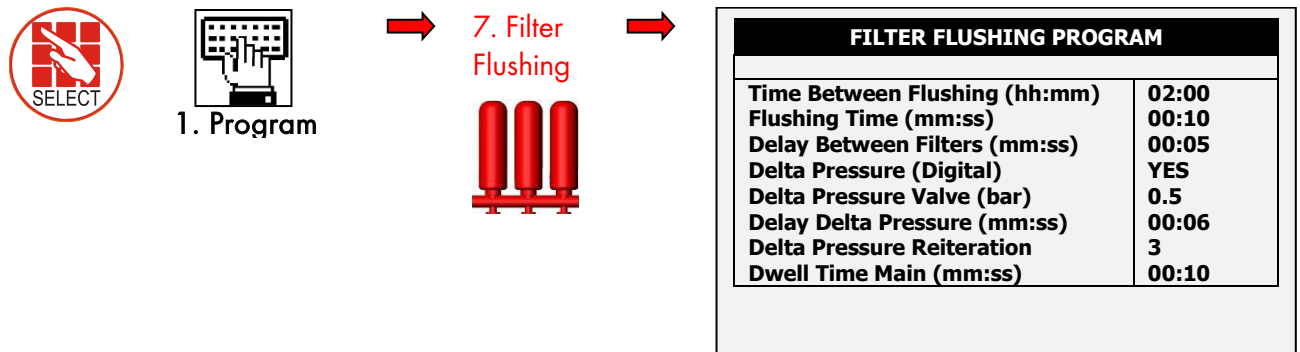

NOTE Filter flush process can start only after main water line is full. The default time is one minute; see Menu 3.3.

| ALARM DEFINITION | |
|--------------------------------------|-------|
| Water Fill Up (min) | 1 |
| Water Leak (m3) | 1.000 |
| Water Leak Period (hh:mm) | 00:30 |
| Identify Leak-Subtr. Meter? | NO |
| ▶ | 3 |
| Dosing Channel Leak Delay(s) | 10 |
| Dosing Channel Leak (Pulse) | 25 |
| Dosing Flow Difference (%) | 10 |
| Missing Pulses For No Flow | -- |
| Stop System Cons. Flow Alarms | 3 |
| # of Irrig. Without Drainage | 2.5 |
| Low Pressure Alarm (bar) | 3 |
| No. Of Short Circ. To Pause | |

NOTE See graph on next page for further information on these fields.

| Item | Description |
|-------------------------------|--|
| Time Between Flushing | Flush occurs after the accumulated irrigation time (between all valves). Break time between irrigation are not included. Only one filter is cleaned at a time. |
| Flush Time | Flush time per filter. |
| Delay Between Filters | Set delay between the flushing of each filter (to build up pressure). |
| Delta Pressure | Set flush by pressure sensor. Pressure at filter inlet/outlet, if there is a significant difference, a filter may be blocked. |
| Delta Pressure Value (sensor) | If there is a differential, (DP signal or Analog DP value), a flush is needed. |
| Delta Pressure Delay | Set delay to verify if there is a definite blockage. |
| Delta Pressure Reiteration | Set to give signal after XX flushes. If Delta Pressure still indicates a blockage, an alarm will be raised. |
| Dwell Time Main | Open main filter valve before flush to balance pressure for a reliable flushing process. |

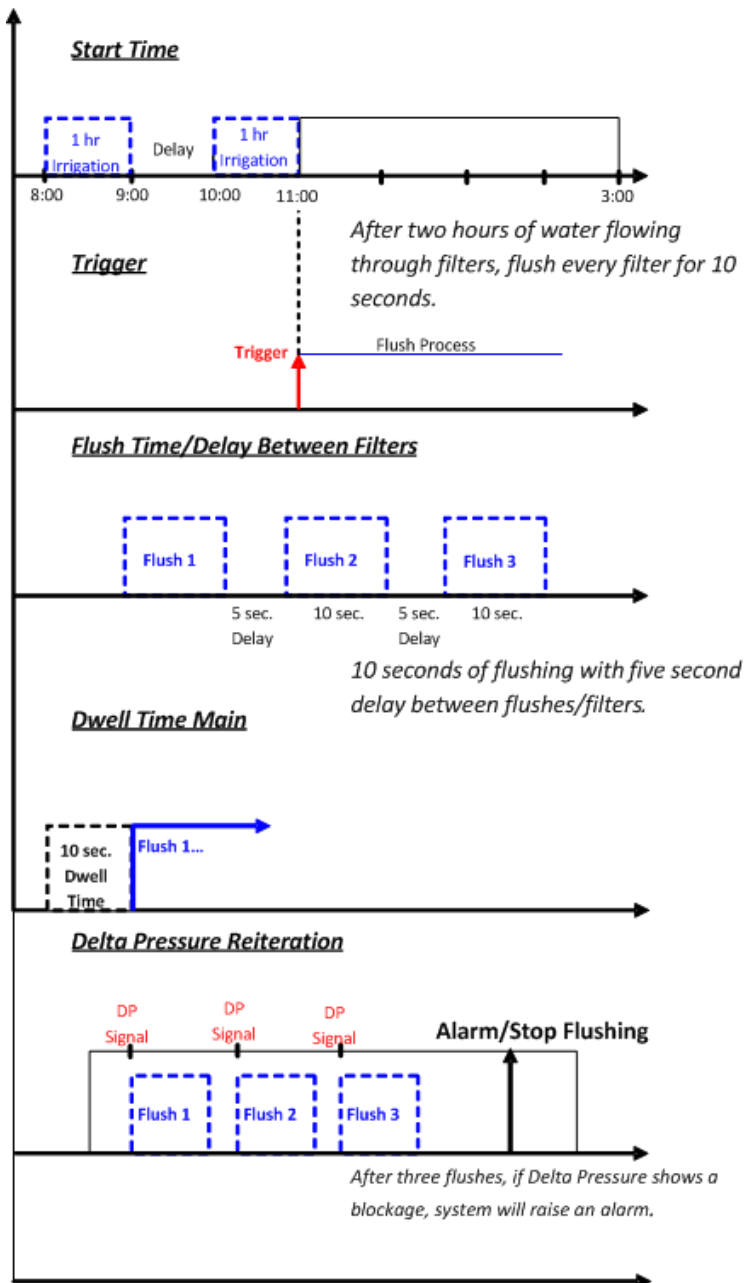

3.12 Cooling

This screen sets a cooling program for cooling/humidification process in greenhouses. This program operates according to temperature, humidity or time (to reduce temperature, increase humidity.)



1. Program

➡ 8. Cooling ➡

Set On/Off time and select sensors

Temp. Sens. 1

+1 of each sensor: uses average of both

Hum. Sens. 1

| COOLING/HUMIDIFICATION PROGRAM | | | |
|--------------------------------|---------------|------------------|-----------|
| Program: 1 | | Status: Cooling | |
| | Below RH | On | Off |
| 1 | 80 | 00:00:10 | 00:00:10 |
| 2 | --- | --:--:-- | --:--:-- |
| Cool# | 1 2 - - - - - | - - - - - | - - - - - |
| Temp. Sens.: 1 -- | | Hum. Sens.: 1 -- | |

OR

| COOLING/HUMIDIFICATION PROGRAM | | | |
|--------------------------------|---------------|-----------------|-----------|
| Program: 1 | | Status: Cooling | |
| | Below RH | On | Off |
| 1 | 80 | 00:00:10 | 00:00:10 |
| 2 | --- | --:--:-- | --:--:-- |
| Cool# | 1 2 - - - - - | - - - - - | - - - - - |
| Temp. Sens.: 1 2 | | Hum. Sens.: 1 2 | |

Dynamic cooling: 2 temp. threshold, same Hum

| COOLING/HUMIDIFICATION PROGRAM | | | |
|--------------------------------|---------------|-----------------|-----------|
| Program: 1 | | Status: Cooling | |
| | From | To | Above t° |
| 1 | 80 | 16:00 | 25.0 |
| 2 | 80 | 16:00 | 35.0 |
| Cool# | 1 2 - - - - - | - - - - - | - - - - - |
| Temp. Sens.: 1 2-- | | Hum. Sens.: 1 2 | |

→

| COOLING/HUMIDIFICATION PROGRAM | | | |
|--------------------------------|---------------|-----------------|-----------|
| Program: 1 | | Status: Cooling | |
| | To | Above t° | Below RH |
| 1 | 16:00 | 25.0 | 80 |
| 2 | 16:00 | 35.0 | 80 |
| Cool# | 1 2 - - - - - | - - - - - | - - - - - |
| Temp. Sens.: 1 2-- | | Hum. Sens.: 1 2 | |

| COOLING/HUMIDIFICATION PROGRAM | | | |
|--------------------------------|---------------|-----------------|-----------|
| Program: 1 | | Status: Cooling | |
| | Below RH | On | Off |
| 1 | 80 | 00:00:10 | 00:00:10 |
| 2 | 80 | 00:00:10 | 00:00:10 |
| Cool# | 1 2 - - - - - | - - - - - | - - - - - |
| Temp. Sens.: 1 2-- | | Hum. Sens.: 1 2 | |

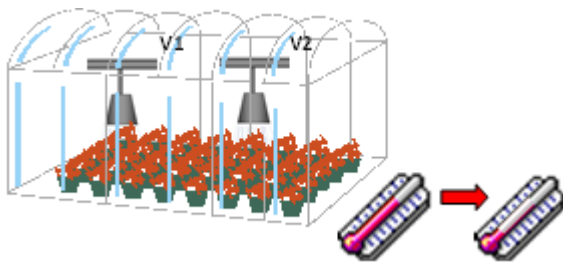

On time is set.

Off time can be controlled according to temp.

High temp.= less off time

Low temp.= more off time

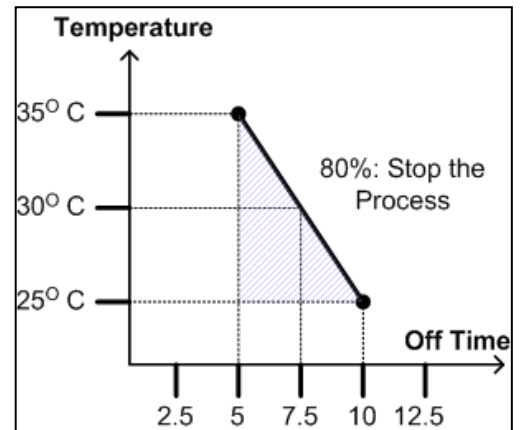

3.13 Misting

Use this screen to control misting in the greenhouse using a timer.



1. Program

Define Start/End time

Define Misting On/Off time

→ 9. Misting →



| MISTING PROGRAM | | | | | |
|-----------------|-----|-------------|-----------|-------------|--------------|
| # | No. | Start hh:mm | End hh:mm | On hh:mm:ss | Off hh:mm:ss |
| 1 | 1 | 08:00 | 16:00 | 00:00:10 | 00:00:05 |
| 2 | -- | --:-- | --:-- | --:--:-- | --:--:-- |
| 3 | -- | --:-- | --:-- | --:--:-- | --:--:-- |
| 4 | -- | --:-- | --:-- | --:--:-- | --:--:-- |
| 5 | -- | --:-- | --:-- | --:--:-- | --:--:-- |
| 6 | -- | --:-- | --:-- | --:--:-- | --:--:-- |
| 7 | -- | --:-- | --:-- | --:--:-- | --:--:-- |
| 8 | -- | --:-- | --:-- | --:--:-- | --:--:-- |
| 9 | -- | --:-- | --:-- | --:--:-- | --:--:-- |
| 10 | -- | --:-- | --:-- | --:--:-- | --:--:-- |



3.14 Water Heating

Use this screen to heat water in cold areas/seasons.



1. Program

- Define Start/End time
- Define Water Temp. ± Difference (dead band) to stop
- Define sensors

→ 10. Water Heating →

| WATER HEATING | |
|-------------------|-------|
| From Time | 08:00 |
| To Time | 16:00 |
| Water Temperature | 20.0 |
| Difference | 2.0 |
| Temp. Sensor #1 | 1 |
| Temp. Sensor #2 | 2 |

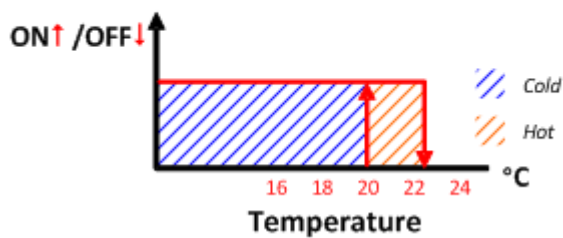
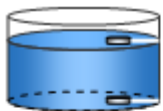

4 Manual Menu

This menu enables manual control over various functions.

- System Pause, page 47
- Start/Stop Program, page 48
- Start/Stop Valve, page 48
- Manual Filter Flush, page 49

4.1 System Pause

Use this function to manually pause the system during an irrigation program; for example if you need to calibrate the EC/pH or fix the pipes.

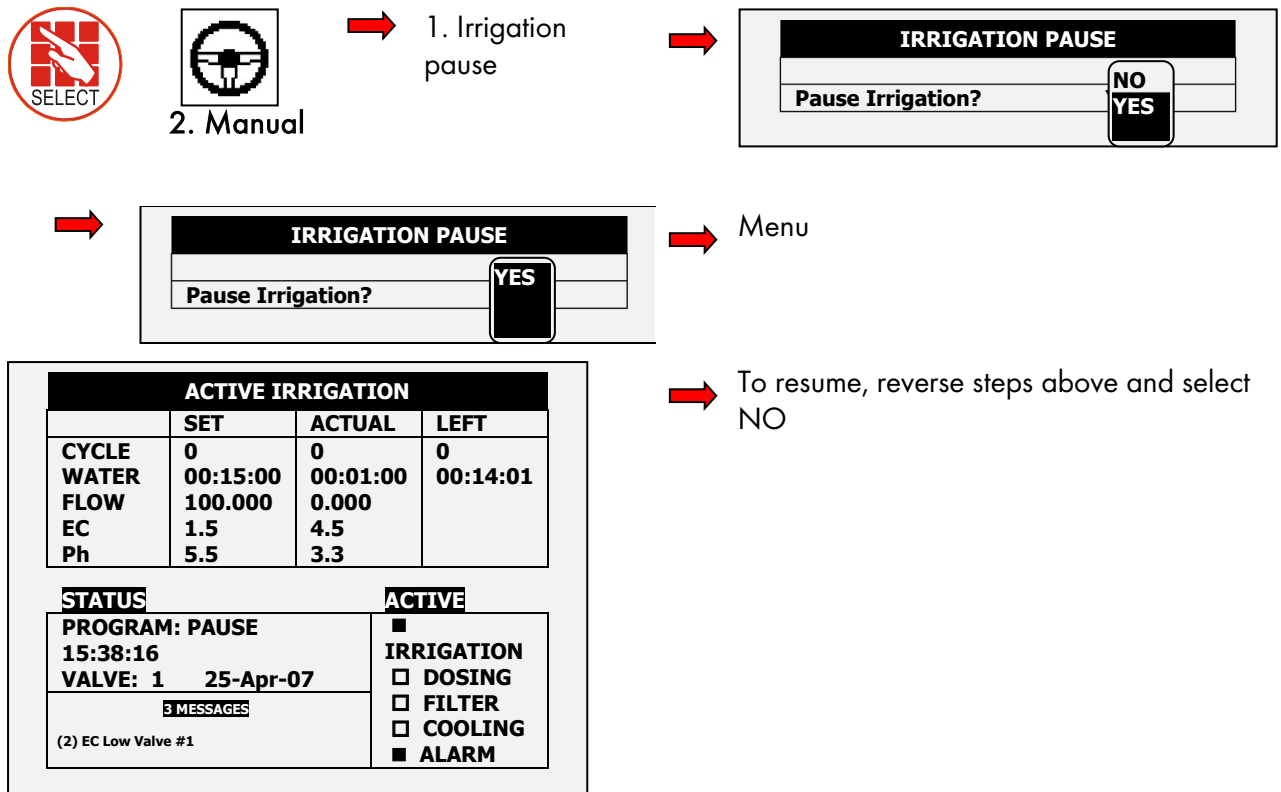

4.2 Start/Stop Program



2. Manual



2. Start/Stop Program



Select Program

| START/STOP PROGRAM | |
|--------------------|---|
| Program: | 1 |



Yes



To resume, reverse steps above and select NO

NOTE Start one cycle only from Program 1.

| DATE : 1-May-07 | | TIME : 10:12:09 | | |
|--------------------------------------|-------|-----------------|-------|---------|
| IRRIGATION PROGRAM | | | | |
| Program: | 1 | Priority: | - | Rad Sum |
| | - | | | |
| Start Time | 07:00 | 08:00 | 10:00 | 13:00 |
| Clock Start | 1 | -- | -- | -- |
| Rad Sum Li. | ---- | 300 | 150 | 300 |
| Min. Time | --:-- | 00:30 | 00:20 | 00:30 |
| Max. Time | --:-- | 01:00 | 01:00 | 01:00 |
| Valve # | 001 | | | |
| Run Time # | 1 | | | |
| Dosing Prog | 1 | | | |
| For Next Screen Press The DOWN Arrow | | | | |

4.3 Start/Stop Valve

Use this screen to manually start/stop a valve.



2. Manual



3. Start/Stop Valve



Select Valve and corresponding Run Time/Dosing program

| START/STOP VALVE | |
|------------------|---|
| Valve | 2 |
| Run Time # | 1 |
| Dosing Program | 1 |



Menu



Yes

To resume, reverse steps above and select NO

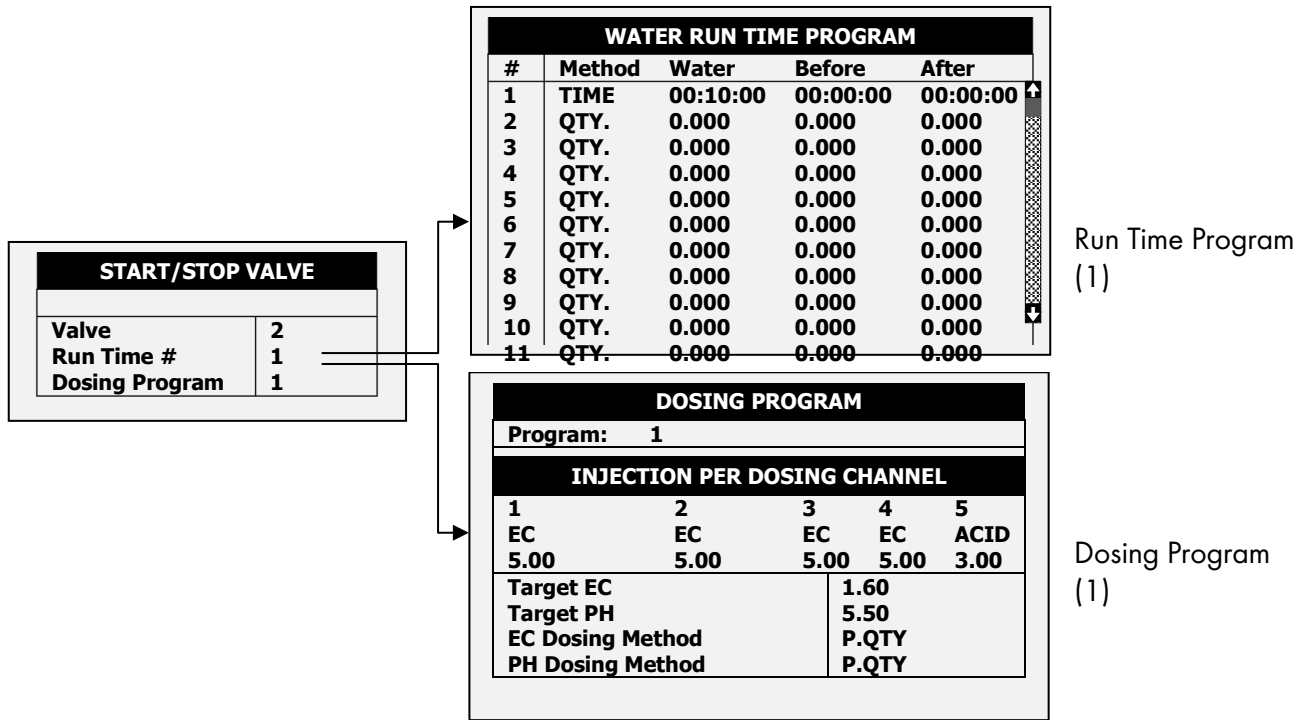

4.4 Manual Filter Flush

Use this screen to activate manual filter flush. Use this function only when the system is irrigating.



2. Manual

4. Filter Flush

Select filters (usually all)

MANUAL FILTER FLUSHING

| | | |
|--------------|--------|--------|
| Which Filter | <None> | <None> |
|--------------|--------|--------|

Menu

MANUAL FILTER FLUSHING

| | |
|------------------------|-------------|
| Which Filter to Flush? | All Filters |
|------------------------|-------------|

Yes Menu Hot Screen 5 to view flushing status

FILTER FLUSHING STATUS

| Item | |
|--------------------------|----------|
| Flush Status | ON |
| Time To Next Flush | --:-- |
| Delta Pressure (Digital) | OFF |
| Flushing Filter No. | 1 |
| Remaining Filters Qty. | 1 |
| Flush Time | 00:07 |
| Current Delta Pressure | ---- |
| Main Filter Delay | 00:00:00 |

NOTE "All Filters" means all filters; however one only one filter is flushed at a time.

NOTE Filter flush process can start only after main water line is full. Default time is one minute as shown in picture below (see Menu 3.3).

| ALARM DEFINITION | |
|-------------------------------------|--------------|
| Water Fill Up (min) | 1 |
| Water Leak (m3) | 1.000 |
| Water Leak Period (hh:mm) | 00:30 |
| Identify Leak-Subtr. Meter? | NO |
| ▶ | 3 |
| Dosing Channel Leak Delay(s) | 10 |
| Dosing Channel Leak (Pulse) | 25 |
| Dosing Flow Difference (%) | 10 |
| Missing Pulses For No Flow | -- |
| Stop System Cons.Flow Alarms | 3 |
| # of Irrig. Without Drainage | 2.5 |
| Low Pressure Alarm (bar) | 3 |
| No. Of Short Circ. To Pause | |

5 Alarm Menu

The Alarm Menu is used to control the Green Field's alarm functions.

- Reset, page 51
- Alarm History, page 52
- Alarm Definition, page 52
- Alarm Setting, page 54
- EC/pH Alarm Definition, page 55
- EC/pH Alarm Setting, page 55
- Radio System Alarm Definition, page 55
- Radio System Alarm View, page 56
- SMS Subscription, page 56

5.1 Reset

Use this function to reset the alarms in case of high flow, low flow, water leak, fertilizer leak, and so forth. Alarms can be reset manually or manually.



3. Alarm



1. Alarm Reset



Option A: Reset manually

| ALARM RESET | | | |
|-----------------------------|--------------------|--------|-------|
| Reset Now? ▶ | | No | |
| Period Of Automatic Reset▶ | | 24 h | |
| Complete Irrig. On Reset? ▶ | | YES | |
| ACTIVE ALARMS | | | |
| No. | Message | Date | Time |
| 1 | High Flow Valve #1 | 25/Apr | 15:49 |



| ALARM RESET | | | |
|-----------------------------|--------------------|--------|-------|
| Reset Now? ▶ | | No | |
| Period Of Automatic Reset ▶ | | 24 h | |
| Complete Irrig. On Reset? ▶ | | YES | |
| ACTIVE ALARMS | | | |
| No. | Message | Date | Time |
| 1 | High Flow Valve #1 | 25/Apr | 15:49 |



Yes

Option B: Automatic reset to check itself every so often as desired:
 ⇒ Select how often system should reset itself



| ALARM RESET | | | |
|-----------------------------|---------|------|------|
| Reset Now? ▾ | | No | |
| Period Of Automatic Reset ▾ | 24 h | 24 h | |
| Complete Irrig. On Reset? ▾ | 12 h | YES | |
| | 6 h | | |
| | 4 h | | |
| ACTIVE ALARMS | | | |
| No. | Message | | Time |
| | | 3 h | |
| | | 2 h | |
| | | 1 h | |
| | | None | |

⇒ "Complete Irrig. On Reset?" Select Yes or No

| ALARM RESET | | | |
|-----------------------------|---------|------|------|
| Reset Now? ▾ | | No | |
| Period Of Automatic Reset ▾ | | 24 h | |
| Complete Irrig. On Reset? ▾ | NO | YES | |
| | | YES | |
| ACTIVE ALARMS | | | |
| No. | Message | Date | Time |
| | | | |

5.2 Alarm History

This is a read-only screen that displays the alarm history.



3. Alarm

⇒ 2. History



| ALARM HISTORY | | | |
|---------------|---------------------|--------|-------|
| No. | Message | Date | Time |
| 112 | EC Low Valve # 1 | 25/Apr | 13:43 |
| 113 | EC Low Valve # 1 | 25/Apr | 13:44 |
| 114 | High Flow Valve # 4 | 25/Apr | 14:26 |
| 115 | Emergency pH Low | 25/Apr | 14:44 |
| 116 | Emergency EC High | 25/Apr | 15:46 |
| 117 | High Flow Valve # 1 | 25/Apr | 15:49 |
| 118 | High Flow Valve # 1 | 25/Apr | 15:52 |
| 119 | High Flow Valve # 4 | 25/Apr | 15:53 |
| 120 | High Flow Valve # 1 | 25/Apr | 15:54 |
| 121 | High Flow Valve # 1 | 25/Apr | 15:55 |

NOTE The system logs up to 250 alarms.

5.3 Alarm Definition

Use this function to define the system alarm thresholds.

NOTE EC/pH thresholds are defined in EC/pH Alarm Definition, page 55.



3. Alarm

⇒ 3. Alarm Definition



Define trigger: deviation from target pressure, flow...

| ALARM DEFINITION | |
|-------------------------------|-------|
| Water Fill Up (min) | 1 |
| Water Leak (m3) | 1.000 |
| Water Leak Period (hh:mm) | 00:30 |
| Identify Leak-Subtr. Meter? | NO |
| | 3 |
| Dosing Channel Leak Delay(s) | 10 |
| Dosing Channel Leak (Pulse) | 25 |
| Dosing Flow Difference (%) | 10 |
| Missing Pulses For No Flow | -- |
| Stop System Cons. Flow Alarms | 3 |
| # of Irrig. Without Drainage | 2.5 |
| Low Pressure Alarm (bar) | 3 |
| No. Of Short Circ. To Pause | |



| ALARM DEFINITION | |
|-------------------------------|-----|
| Dosing Channel Leak Delay(s) | 3 |
| Dosing Channel Leak (Pulse) | 10 |
| Dosing Flow Difference (%) | 25 |
| Missing Pulses For No Flow | 10 |
| Stop System Cons. Flow Alarms | 3 |
| # of Irrig. Without Drainage | 3 |
| Low Pressure Alarm (bar) | 2.5 |
| No. Of Shor Cir. To Pause | 3 |
| Short Output Level (60-350) | 300 |
| Short O. Level EXP1 (60-350) | 300 |
| Short O. Level EXP2 (60-350) | 300 |
| Short O. Level EXP3 (60-350) | 300 |

| Item | Description |
|-------------------------------|--|
| Water Fill Up (min) | Time of filling the main irrigation line. In that time, the system will ignore high flow alarm and won't implement a filter flushing process. |
| Water Leak (m3 or Gal) | Quantity of water leaking while the system is in idle. |
| Water Leak Period (hh:mm) | Time frame to measure the water leak quantity Example: 1m3 leaks in less than 30 minutes |
| Identify Leak-Subtr. Meter? | This setting relevant only when working in "Water source" method. User can ignore or identify a water leak. |
| Dosing Channel Leak Delay (s) | Delay between switching off a dosing channel and generating dosing leak alarm. |
| Dosing Channel Leak (Pulse) | Number of pulses (by dosing meter) during the delay above to generate an alarm. Example: 10 pulses in 3 seconds generate an alarm. |
| Dosing Flow Difference (%) | Difference between calculated and measured dosing channel flow. Example: Dosing Channel 1 defined by technician as 100 liter/hour, but if the system measured less than 75 liter/hour or more than 125 liter/hour, an alarm will be generated. |

| ALARM DEFINITION | |
|-------------------------------|-------|
| Water Fill Up (min) | 1 |
| Water Leak (m3) | 1.000 |
| Water Leak Period (hh:mm) | 00:30 |
| Identify Leak-Subtr. Meter? | NO |
| | 3 |
| Dosing Channel Leak Delay(s) | 10 |
| Dosing Channel Leak (Pulse) | 25 |
| Dosing Flow Difference (%) | 10 |
| Missing Pulses For No Flow | -- |
| Stop System Cons. Flow Alarms | 3 |
| # of Irrig. Without Drainage | 2.5 |
| Low Pressure Alarm (bar) | 3 |
| No. Of Short Circ. To Pause | |



| ALARM DEFINITION | |
|-------------------------------|-----|
| Dosing Channel Leak Delay(s) | 3 |
| Dosing Channel Leak (Pulse) | 10 |
| Dosing Flow Difference (%) | 25 |
| Missing Pulses For No Flow | 10 |
| Stop System Cons. Flow Alarms | 3 |
| # of Irrig. Without Drainage | 3 |
| Low Pressure Alarm (bar) | 2.5 |
| No. Of Shor Cir. To Pause | 3 |
| Short Output Level (60-350) | 300 |
| Short O. Level EXP1 (60-350) | 300 |
| Short O. Level EXP2 (60-350) | 300 |
| Short O. Level EXP3 (60-350) | 300 |

Table continued...

| Item | Description |
|-------------------------------------|---|
| Missing Pulses For No Flow | Number of missing pulses before the system will generate a No Flow alarm. The system calculates the expected time between pulses of water meter and if a certain time elapsed without receiving the desired number of pulses, then generate an alarm. |
| Stop System Consecutive Flow Alarms | Number of consecutive flow alarms of the same type (high flow, low flow etc.) but different valves before the system is stopped. Example: High flow at valve 1 ->High flow at valve 2->High flow at valve 3 = 3 consecutive High flow, then system stops. |
| # of Irrigations Without Drainage | Number of irrigations given without measuring drainage, above which an alarm will be generated. Common reasons: Irrigation quantity is too small so there is not enough drain, or drain measurement malfunction because of technical problem. |
| Low Pressure Alarm (bar/psi) | Minimum system pressure before generate an alarm. |
| Num. Of Short Circ. To Pause | Number of short circuit (in field device) alarms measured before the system is paused. |
| Short Output Level (60-350) | Define the A/D threshold value to be considered as a short circuit (For technician use only). |
| Short O. Level EXT1 (60 - 350) | Define the A/D threshold value to be considered as a short circuit for Extension box no. 1 (For technician use only) |
| Short O. Level EXT2 (60 - 350) | Define the A/D threshold value to be considered as a short circuit for Extension box no. 2 (For technician use only) |
| Short O. Level EXT3 (60 - 350) | Define the A/D threshold value to be considered as a short circuit for Extension box no. 3 (For technician use only) |

5.4 Alarm Setting

Use this function to define what actions are taken in the event of an alarm.

NOTE EC/pH settings are defined in EC/pH Alarm Setting, page 55.



3. Alarm



4. Alarm Setting

- Define alarm action: automatically stop or continue.
- Delay before generating alarm.
- Alarm output activation: YES/NO (siren, light).



| ALARM SETTING | | | | |
|---------------|-------|--------|-------------|--------------|
| Description | Irr. | Dose | Delay mm:ss | Alarm Active |
| High Flow | CONT. | STOP | 01:00 | NO |
| Low Flow | STOP | STOP | 01:00 | YES |
| No Flow | STOP | STOP | ---- | YES |
| D. Ch. Leak | STOP | STOP | 30:00 | YES |
| D. Ch. Fault | STOP | STOP | 01:00 | YES |
| Ext. Pause | PAUSE | IRRIG. | 00:30 | YES |
| D. Boos.Prot. | CONT. | STOP | 01:00 | YES |
| Low Pressure | STOP | STOP | 01:00 | YES |
| R.U. Error | STOP | STOP | 01:00 | YES |
| Host Error | STOP | STOP | 01:00 | YES |

5.5 EC/pH Alarm Definition

Use this function to define the EC/pH alarm thresholds.



3. Alarm



5. EC/pH Alarm Definition

- Delta Low: Maximum differences below EC, pH and EC Pre-Control targets.
- Delta High: Maximum difference above EC, pH and EC Pre-Control targets.
- Emergency: Critical values of High EC and Low pH that stop the system after 1 min.

| EC/pH ALARM DEFINITION | |
|-------------------------------|-----|
| Delta EC Low | 0.5 |
| Delta EC High | 0.5 |
| Delta pH Low | 0.5 |
| Delta pH High | 0.5 |
| Delta EC-Pre Control Low | 0.5 |
| Delta EC-Pre Control High | 0.5 |
| Emergency EC High (1 Min.Dly) | 5.0 |
| Emergency pH Low (1 Min.Dly) | 2.0 |

5.6 EC/pH Alarm Setting

Use this function to set the EC/pH alarm and action definitions in the event of an EC/pH alarm.



3. Alarm



6. EC/pH Alarm Setting

- Define EC/pH alarm action: automatically stop or continue.
- Delay before generating alarm.
- Alarm output activation: YES/NO (siren, light).

| EC/pH ALARM SETTING | | | | |
|---------------------|------|------|-------------|--------------|
| Description | Irr. | Dose | Delay mm:ss | Alarm Active |
| EC High/Fail | STOP | STOP | 01:00 | YES |
| EC Low | STOP | STOP | 01:00 | YES |
| pH High | STOP | STOP | 01:00 | YES |
| pH Low/Fail | STOP | STOP | 01:00 | YES |
| EC-P. Hi/Fail | STOP | STOP | 01:00 | YES |
| EC-Pre. Low | STOP | STOP | 01:00 | YES |
| E. Tank Fresh | STOP | STOP | 01:00 | YES |
| E. Tank Drain | STOP | STOP | 01:00 | YES |
| EC Sen. Dif. | STOP | STOP | 01:00 | YES |
| pH Sen Dif. | STOP | STOP | 01:00 | YES |

5.7 Radio System Alarm Definition

Use this function to define Radio Systems alarm activity and notification.

CAUTION IMPORTANT: For the Radio System to work properly, you **MUST** define in the 6.2 SYSTEM SETUP menu - Remote Unit type parameter SN/RF Net.



3. Alarm



7. Radio Sys Alarm Definition

| RADIO SYS. ALARM DEFINITION | | | |
|-----------------------------|-------------|--------|--------|
| Alarm Type | Delay mm:ss | Active | Inform |
| RTU | | | |
| Vbatt failure | 00:00 | YES | YES |
| Vbatt low | 00:00 | NO | YES |
| Vbatt warn | 00:00 | NO | YES |
| Cap failure | 00:00 | NO | YES |
| Card failure | 00:00 | NO | YES |
| I/O Open | 00:00 | NO | YES |
| I/O Shor | 00:00 | NO | YES |
| HOST | | | |
| Over current | 00:00 | NO | YES |

- **ACTIVE** defines if an alarm enables a decision regarding the irrigation program (YES / NO)
- The **INFORM** column defines if the system notifies the user of the alarm occurrence (YES / NO)

5.8 Radio System Alarm View

This screen displays the current alarm status of the Radio System.



➔ 8. Radio Sys Alarm View

| RADIO SYS. Alarm view | | | | |
|-----------------------|----------|------|-----------|------|
| Unit | S/N | Comm | Vin state | Card |
| HOST | 0128 | OK | - | - |
| BASE | 0117 | FAIL | - | - |
| RTU | 0236 | OK | - | 3.1 |
| RTU | 0115.3.4 | - | OK | |
| RTU | 0513.4.1 | - | FAIL | |
| RTU | 0198 | - | WARN | |
| RTU | 0555.3.1 | - | LOW | |
| RTU | ---- | - | - | |
| RTU | ---- | - | - | |
| RTU | ---- | - | - | |

The **S/N** column is the unit number. When an *Open Circuit or Short Circuit* alarm is detected, the system also displays the card number and the input/output number that is problematic.

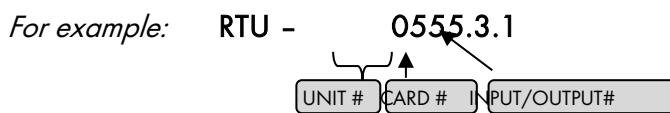

Exiting and re-entering refreshes the alarm status screen.

5.9 SMS Subscription

Use this screen to define which alarms are sent to each subscriber.

NOTE Define subscribers need in the 6.11 EDIT SMS PHONEBOOK menu.



➔ 9. SMS Subscription

| SMS SUBSCRIPTION | | |
|------------------|----------|------|
| Alarm/Group | ADAM | JAKE |
| *Hardware | PRIORITY | YES |
| *System # | PRIORITY | YES |
| *Hydraulic# | PRIORITY | YES |
| *Dosing # | PRIORITY | YES |
| HIGH FLOW VALVE# | YES | NO |
| LOW FLOW VAVLE# | YES | NO |
| WATER LEAK | YES | NO |
| LOW PRES PRESSOS | YES | NO |
| DELTA PRESSURE | NO | NO |
| SYS LOW PRESSURE | YES | YES |





Define which subscriber receives an SMS if there is an active alarm within the listed alarms or group of alarms:

- **NO:** Do not send an SMS for this alarm
- **YES:** Send an SMS for this alarm according to the “Send period” parameter defined in the SMS SETUP menu
- **PRIORITY:** Send an SMS for this alarm as soon as it appears regardless of “Send Period” time constraints

NOTE Refer to the SETUP section (Menus 6.11-6.13) in the Installation manual for more information on the SMS feature.

6 History Menu

The History Menu consists of read-only screens detailing the system's history data (measurements, settings, processes, events, graphs and so forth). The History Menu provides extensive information regarding measurements and processes performed by the Green Field.

|  |  <p>4. History</p> | <p>11. Sensor Log</p> | <table border="1"> <thead> <tr> <th colspan="5">SENSORS LOG</th> </tr> <tr> <th>Date</th> <th>Time</th> <th>Avg. Hum.</th> <th>-EC-</th> <th>-pH-</th> </tr> </thead> <tbody> <tr><td>25/Apr</td><td>16:00</td><td>----</td><td>3.0</td><td>4.1</td></tr> <tr><td>25/Apr</td><td>15:00</td><td>----</td><td>1.4</td><td>4.8</td></tr> <tr><td>25/Apr</td><td>14:00</td><td>----</td><td>1.1</td><td>5.4</td></tr> <tr><td>22/Apr</td><td>16:00</td><td>----</td><td>1.0</td><td>5.1</td></tr> <tr><td>22/Apr</td><td>16:00</td><td>----</td><td>1.0</td><td>5.1</td></tr> <tr><td>22/Apr</td><td>15:00</td><td>----</td><td>1.0</td><td>5.1</td></tr> <tr><td>22/Apr</td><td>15:00</td><td>----</td><td>1.0</td><td>5.1</td></tr> <tr><td>22/Apr</td><td>14:00</td><td>----</td><td>1.0</td><td>5.1</td></tr> <tr><td>22/Apr</td><td>14:00</td><td>----</td><td>1.0</td><td>5.1</td></tr> <tr><td>22/Apr</td><td>13:00</td><td>----</td><td>1.0</td><td>5.1</td></tr> </tbody> </table> | SENSORS LOG | | | | | Date | Time | Avg. Hum. | -EC- | -pH- | 25/Apr | 16:00 | ---- | 3.0 | 4.1 | 25/Apr | 15:00 | ---- | 1.4 | 4.8 | 25/Apr | 14:00 | ---- | 1.1 | 5.4 | 22/Apr | 16:00 | ---- | 1.0 | 5.1 | 22/Apr | 16:00 | ---- | 1.0 | 5.1 | 22/Apr | 15:00 | ---- | 1.0 | 5.1 | 22/Apr | 15:00 | ---- | 1.0 | 5.1 | 22/Apr | 14:00 | ---- | 1.0 | 5.1 | 22/Apr | 14:00 | ---- | 1.0 | 5.1 | 22/Apr | 13:00 | ---- | 1.0 | 5.1 |
|---|---|-----------------------|---|-------------|--------|--------|-----------|------|-----------|-----------|-----------|------|--------|--------|---|-------|-------|--------|--------|-------|-------|-------|--------|--------|---|------|-----|--------|--------|-------|------|-----|--------|--------|-------|------|-----|--------|--------|-------|------|-----|--------|--------|-------|------|-----|--------|--------|-------|------|-----|--------|--------|-------|------|-----|--------|--------|-------|------|-----|--|
| SENSORS LOG | | | | | | | | | | | | | | | | | | | | | | | | | | | | | | | | | | | | | | | | | | | | | | | | | | | | | | | | | | | | | | | |
| Date | Time | Avg. Hum. | -EC- | -pH- | | | | | | | | | | | | | | | | | | | | | | | | | | | | | | | | | | | | | | | | | | | | | | | | | | | | | | | | | | | |
| 25/Apr | 16:00 | ---- | 3.0 | 4.1 | | | | | | | | | | | | | | | | | | | | | | | | | | | | | | | | | | | | | | | | | | | | | | | | | | | | | | | | | | | |
| 25/Apr | 15:00 | ---- | 1.4 | 4.8 | | | | | | | | | | | | | | | | | | | | | | | | | | | | | | | | | | | | | | | | | | | | | | | | | | | | | | | | | | | |
| 25/Apr | 14:00 | ---- | 1.1 | 5.4 | | | | | | | | | | | | | | | | | | | | | | | | | | | | | | | | | | | | | | | | | | | | | | | | | | | | | | | | | | | |
| 22/Apr | 16:00 | ---- | 1.0 | 5.1 | | | | | | | | | | | | | | | | | | | | | | | | | | | | | | | | | | | | | | | | | | | | | | | | | | | | | | | | | | | |
| 22/Apr | 16:00 | ---- | 1.0 | 5.1 | | | | | | | | | | | | | | | | | | | | | | | | | | | | | | | | | | | | | | | | | | | | | | | | | | | | | | | | | | | |
| 22/Apr | 15:00 | ---- | 1.0 | 5.1 | | | | | | | | | | | | | | | | | | | | | | | | | | | | | | | | | | | | | | | | | | | | | | | | | | | | | | | | | | | |
| 22/Apr | 15:00 | ---- | 1.0 | 5.1 | | | | | | | | | | | | | | | | | | | | | | | | | | | | | | | | | | | | | | | | | | | | | | | | | | | | | | | | | | | |
| 22/Apr | 14:00 | ---- | 1.0 | 5.1 | | | | | | | | | | | | | | | | | | | | | | | | | | | | | | | | | | | | | | | | | | | | | | | | | | | | | | | | | | | |
| 22/Apr | 14:00 | ---- | 1.0 | 5.1 | | | | | | | | | | | | | | | | | | | | | | | | | | | | | | | | | | | | | | | | | | | | | | | | | | | | | | | | | | | |
| 22/Apr | 13:00 | ---- | 1.0 | 5.1 | | | | | | | | | | | | | | | | | | | | | | | | | | | | | | | | | | | | | | | | | | | | | | | | | | | | | | | | | | | |
| <table border="1"> <thead> <tr> <th colspan="5">SENSORS LOG</th> </tr> <tr> <th>Date</th> <th>Time</th> <th>Avg. Hum.</th> <th>-EC-</th> <th>-pH-</th> </tr> </thead> <tbody> <tr><td>25/Apr</td><td>16:00</td><td>----</td><td>3.0</td><td>4.1</td></tr> <tr><td>25/Apr</td><td>15:00</td><td>----</td><td>1.4</td><td>4.8</td></tr> <tr><td>25/Apr</td><td>14:00</td><td>----</td><td>1.1</td><td>5.4</td></tr> <tr><td>22/Apr</td><td>16:00</td><td>----</td><td>1.0</td><td>5.1</td></tr> <tr><td>22/Apr</td><td>16:00</td><td>----</td><td>1.0</td><td>5.1</td></tr> <tr><td>22/Apr</td><td>15:00</td><td>----</td><td>1.0</td><td>5.1</td></tr> <tr><td>22/Apr</td><td>15:00</td><td>----</td><td>1.0</td><td>5.1</td></tr> <tr><td>22/Apr</td><td>14:00</td><td>----</td><td>1.0</td><td>5.1</td></tr> <tr><td>22/Apr</td><td>14:00</td><td>----</td><td>1.0</td><td>5.1</td></tr> <tr><td>22/Apr</td><td>13:00</td><td>----</td><td>1.0</td><td>5.1</td></tr> </tbody> </table> <div data-bbox="311 1142 582 1332" style="border: 1px solid black; padding: 5px; margin-top: 10px;"> <p>?</p> <p>Help Graph</p> </div> | | | SENSORS LOG | | | | | Date | Time | Avg. Hum. | -EC- | -pH- | 25/Apr | 16:00 | ---- | 3.0 | 4.1 | 25/Apr | 15:00 | ---- | 1.4 | 4.8 | 25/Apr | 14:00 | ---- | 1.1 | 5.4 | 22/Apr | 16:00 | ---- | 1.0 | 5.1 | 22/Apr | 16:00 | ---- | 1.0 | 5.1 | 22/Apr | 15:00 | ---- | 1.0 | 5.1 | 22/Apr | 15:00 | ---- | 1.0 | 5.1 | 22/Apr | 14:00 | ---- | 1.0 | 5.1 | 22/Apr | 14:00 | ---- | 1.0 | 5.1 | 22/Apr | 13:00 | ---- | 1.0 | 5.1 | <p>Select sensors using +/- key (no more than 3 per graph)</p> |
| SENSORS LOG | | | | | | | | | | | | | | | | | | | | | | | | | | | | | | | | | | | | | | | | | | | | | | | | | | | | | | | | | | | | | | | |
| Date | Time | Avg. Hum. | -EC- | -pH- | | | | | | | | | | | | | | | | | | | | | | | | | | | | | | | | | | | | | | | | | | | | | | | | | | | | | | | | | | | |
| 25/Apr | 16:00 | ---- | 3.0 | 4.1 | | | | | | | | | | | | | | | | | | | | | | | | | | | | | | | | | | | | | | | | | | | | | | | | | | | | | | | | | | | |
| 25/Apr | 15:00 | ---- | 1.4 | 4.8 | | | | | | | | | | | | | | | | | | | | | | | | | | | | | | | | | | | | | | | | | | | | | | | | | | | | | | | | | | | |
| 25/Apr | 14:00 | ---- | 1.1 | 5.4 | | | | | | | | | | | | | | | | | | | | | | | | | | | | | | | | | | | | | | | | | | | | | | | | | | | | | | | | | | | |
| 22/Apr | 16:00 | ---- | 1.0 | 5.1 | | | | | | | | | | | | | | | | | | | | | | | | | | | | | | | | | | | | | | | | | | | | | | | | | | | | | | | | | | | |
| 22/Apr | 16:00 | ---- | 1.0 | 5.1 | | | | | | | | | | | | | | | | | | | | | | | | | | | | | | | | | | | | | | | | | | | | | | | | | | | | | | | | | | | |
| 22/Apr | 15:00 | ---- | 1.0 | 5.1 | | | | | | | | | | | | | | | | | | | | | | | | | | | | | | | | | | | | | | | | | | | | | | | | | | | | | | | | | | | |
| 22/Apr | 15:00 | ---- | 1.0 | 5.1 | | | | | | | | | | | | | | | | | | | | | | | | | | | | | | | | | | | | | | | | | | | | | | | | | | | | | | | | | | | |
| 22/Apr | 14:00 | ---- | 1.0 | 5.1 | | | | | | | | | | | | | | | | | | | | | | | | | | | | | | | | | | | | | | | | | | | | | | | | | | | | | | | | | | | |
| 22/Apr | 14:00 | ---- | 1.0 | 5.1 | | | | | | | | | | | | | | | | | | | | | | | | | | | | | | | | | | | | | | | | | | | | | | | | | | | | | | | | | | | |
| 22/Apr | 13:00 | ---- | 1.0 | 5.1 | | | | | | | | | | | | | | | | | | | | | | | | | | | | | | | | | | | | | | | | | | | | | | | | | | | | | | | | | | | |
| <table border="1"> <thead> <tr> <th colspan="2">GRAPH SELECT</th> </tr> <tr> <th>Option</th> <th>Yes/No</th> </tr> </thead> <tbody> <tr><td>Avg. Temp</td><td>.</td></tr> <tr><td>Avg. Hum.</td><td>√</td></tr> <tr><td>-EC-</td><td>√</td></tr> <tr><td>-pH-</td><td></td></tr> </tbody> </table> | | | GRAPH SELECT | | Option | Yes/No | Avg. Temp | . | Avg. Hum. | √ | -EC- | √ | -pH- | | <div data-bbox="869 1355 1077 1467" style="display: flex; align-items: center;">   </div> <p><i>NOTE Press the Mode/Zone Key to view the graphs.</i></p> | | | | | | | | | | | | | | | | | | | | | | | | | | | | | | | | | | | | | | | | | | | | | | | | |
| GRAPH SELECT | | | | | | | | | | | | | | | | | | | | | | | | | | | | | | | | | | | | | | | | | | | | | | | | | | | | | | | | | | | | | | | |
| Option | Yes/No | | | | | | | | | | | | | | | | | | | | | | | | | | | | | | | | | | | | | | | | | | | | | | | | | | | | | | | | | | | | | | |
| Avg. Temp | . | | | | | | | | | | | | | | | | | | | | | | | | | | | | | | | | | | | | | | | | | | | | | | | | | | | | | | | | | | | | | | |
| Avg. Hum. | √ | | | | | | | | | | | | | | | | | | | | | | | | | | | | | | | | | | | | | | | | | | | | | | | | | | | | | | | | | | | | | | |
| -EC- | √ | | | | | | | | | | | | | | | | | | | | | | | | | | | | | | | | | | | | | | | | | | | | | | | | | | | | | | | | | | | | | | |
| -pH- | | | | | | | | | | | | | | | | | | | | | | | | | | | | | | | | | | | | | | | | | | | | | | | | | | | | | | | | | | | | | | | |
| <div data-bbox="199 1724 247 1769" style="color: red;">➔</div> <table border="1"> <thead> <tr> <th colspan="2">-EC-</th> <th colspan="2">-</th> <th colspan="2">-pH-</th> </tr> </thead> <tbody> <tr> <td>5.0</td><td>4.0</td><td>3.0</td><td>2.0</td><td>1.0</td><td></td> </tr> <tr> <td>16:00</td><td>16:00</td><td>14:00</td><td>12:00</td><td>09:00</td><td></td> </tr> <tr> <td>25/04</td><td>22/04</td><td>22/04</td><td>22/04</td><td>22/04</td><td></td> </tr> </tbody> </table> | -EC- | | - | | -pH- | | 5.0 | 4.0 | 3.0 | 2.0 | 1.0 | | 16:00 | 16:00 | 14:00 | 12:00 | 09:00 | | 25/04 | 22/04 | 22/04 | 22/04 | 22/04 | | <p><i>NOTE Use ↑↓ arrow keys to zoom in/out. Use ←→ arrow keys to scroll.</i></p> | | | | | | | | | | | | | | | | | | | | | | | | | | | | | | | | | | | | | | |
| -EC- | | - | | -pH- | | | | | | | | | | | | | | | | | | | | | | | | | | | | | | | | | | | | | | | | | | | | | | | | | | | | | | | | | | | |
| 5.0 | 4.0 | 3.0 | 2.0 | 1.0 | | | | | | | | | | | | | | | | | | | | | | | | | | | | | | | | | | | | | | | | | | | | | | | | | | | | | | | | | | | |
| 16:00 | 16:00 | 14:00 | 12:00 | 09:00 | | | | | | | | | | | | | | | | | | | | | | | | | | | | | | | | | | | | | | | | | | | | | | | | | | | | | | | | | | | |
| 25/04 | 22/04 | 22/04 | 22/04 | 22/04 | | | | | | | | | | | | | | | | | | | | | | | | | | | | | | | | | | | | | | | | | | | | | | | | | | | | | | | | | | | |



4. History

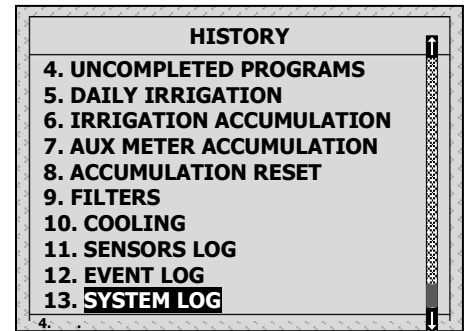
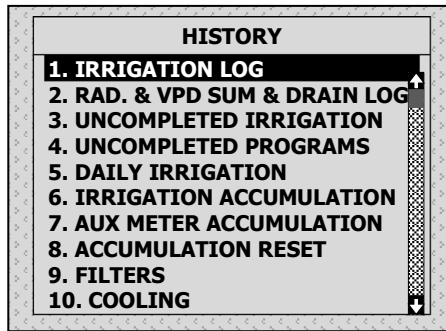

6.1 Irrigation Log

- The Irrigation Log table includes up to 200 rows of the last irrigations' data. Each row includes information regarding a specific irrigation.
To view additional information, use the left/right arrow keys.
To switch between dosing quantities or time simply press the '+/-' key.

| DATE : 24-Dec-06 | | TIME : 17:17:20 | | |
|------------------|-------|-----------------|---------|---------|
| IRRIGATION LOG | | | | |
| Date | Time | V1 | Chan. 1 | Chan. 2 |
| 23/Dec | 17:21 | 255 | 3.58 | 3.60 |
| 23/Dec | 17:32 | 254 | 2.63 | 2.81 |
| 23/Dec | 17:42 | 217 | 3.58 | 3.59 |
| 23/Dec | 17:52 | 115 | 3.41 | 3.44 |
| 23/Dec | 18:02 | 219 | 2.64 | 2.81 |
| 24/Dec | 14:50 | 255 | 3.58 | 3.59 |
| 24/Dec | 15:00 | 254 | 2.63 | 2.81 |
| 24/Dec | 15:10 | 217 | 3.57 | 3.60 |
| 24/Dec | 15:20 | 115 | 3.52 | 2.82 |
| 24/Dec | 15:30 | 219 | 3.52 | 2.82 |

NOTE Water quantity is measured in m³ or gallons; duration is measured by time; flow is measured in m³/h or gallon/m; dosing quantity is measured in liters or gallons.

| Item | Description |
|----------|--|
| Date | Date in which the irrigation started. |
| Time | Time in which the irrigation started. |
| Valve | Leading valve; the first valve set for the group of valves |
| Reason | Specification of the irrigation triggers; time, condition, Rad Sum, etc. |
| Water | Irrigation quantity (m ³ or gallon) or irrigation time. |
| Duration | Irrigation duration (hh:mm:ss). |
| Flow | Average flow throughout the irrigation cycle. |
| Chan. # | Dosing quantities per channel (liter or gallon) or dosing time. |
| EC Low | Lowest EC value recorded during irrigation. |
| EC Avg. | Average EC value recorded during irrigation. |
| EC High | Highest EC value recorded during irrigation. |
| pH Low | Lowest pH value recorded during irrigation. |

| Item | Description |
|---------|--|
| pH Avg. | Average pH value recorded during irrigation. |
| pH High | Highest pH value recorded during irrigation. |

6.2 RAD. & VPD SUM & DRAIN LOG

| DATE : 21-Dec-06 | | TIME : 14:51:18 | | |
|----------------------|-------|-----------------|--------|-------|
| RAD. SUM & DRAIN LOG | | | | |
| Date | Time | V1 | Reason | Water |
| 20/Dec | 17:26 | 254 | Rad | 1.400 |
| 20/Dec | 17:26 | 217 | Sum | 1.400 |
| 20/Dec | 17:27 | 115 | Rad | 1.400 |
| 20/Dec | 17:27 | 219 | Sum | 1.400 |
| 20/Dec | 17:27 | 255 | Rad | 1.400 |
| 20/Dec | 17:28 | 254 | Sum | 0.800 |
| 20/Dec | 17:28 | 217 | Rad | 0.800 |
| 20/Dec | 17:28 | 115 | Sum | 0.800 |
| 20/Dec | 17:28 | 255 | Sum | 0.800 |

| DATE : 21-Dec-06 | | TIME : 14:51:33 | | |
|------------------|-------|-----------------|---------|-------|
| IRRIGATION LOG | | | | |
| Date | Time | V1 | Drain % | Drain |
| 20/Dec | 17:26 | 254 | 100.00 | 1450 |
| 20/Dec | 17:26 | 217 | 92.86 | 1300 |
| 20/Dec | 17:27 | 115 | 78.57 | 1100 |
| 20/Dec | 17:27 | 219 | 100.00 | 1400 |
| 20/Dec | 17:27 | 255 | ----- | 0 |
| 20/Dec | 17:28 | 254 | 62.50 | 500 |
| 20/Dec | 17:28 | 217 | 100.00 | 800 |
| 20/Dec | 17:28 | 115 | 18.75 | 150 |
| 20/Dec | 17:28 | 255 | ----- | 0 |

| DATE : 21-Dec-06 | | TIME : 14:51:45 | | |
|------------------|-------|-----------------|---------|----------|
| IRRIGATION LOG | | | | |
| Date | Time | V1 | Rad Sum | Interval |
| 20/Dec | 17:26 | 254 | 19 | ---- |
| 20/Dec | 17:26 | 217 | 19 | ---- |
| 20/Dec | 17:27 | 115 | 19 | 1 |
| 20/Dec | 17:27 | 219 | 19 | 1 |
| 20/Dec | 17:27 | 255 | 19 | 2 |
| 20/Dec | 17:28 | 254 | 19 | ---- |
| 20/Dec | 17:28 | 217 | 19 | ---- |
| 20/Dec | 17:28 | 115 | 19 | ---- |
| 20/Dec | 17:29 | 219 | 19 | 1 |
| 20/Dec | 17:29 | 255 | 15 | 1 |

| Item | Description |
|----------|---|
| Time | Time irrigation started. |
| Valve | Leading valve. |
| Reason | Specification of the irrigation triggers; time, condition, Rad Sum, etc. |
| Water | Irrigation quantity (m ³ or gallon) or irrigation time. |
| Drain % | Percentage of drain for relevant irrigation cycle. |
| Drain | Drain quantity related to relevant irrigation. |
| Rad Sum | Accumulated radiation sum level when irrigation started. |
| Interval | Time (in minutes) since last irrigation cycle. Refers to the last irrigation of a specific valve. |

6.3 Uncompleted Irrigation

The Uncompleted Irrigation table provides information of irrigations that were started but could not be completed due to a failure. To understand why irrigation was not completed, it is advisable to cross-reference between this table and the Alarm Definition in section 4.3. The Uncompleted Irrigation table

consists of up to 200 lines. Note that if the letter 'C' appears, it refers to a program that was triggered by condition program.

| UNCOMPLETED IRRIGATION | | | | | | |
|------------------------|-----------|---------------|-------------|--------|------------|--------------|
| No. | Date | Time hh:mm | Prog No. | V1.No. | Run No. | Dose Prog |
| 1 | 20-Dec-06 | 09:05 | 1 | 51+ | 1 | 1 |
| 2 | 20-Dec-06 | 09:25 | 2 | 1 | 1 | -- |

Each line includes information regarding when the irrigation was stopped and added to the uncompleted irrigations table.

| Item | Description |
|------------|---|
| Date | Date in which the current line was added to the uncompleted irrigation table. |
| Time | Time in which the current line was added to the uncompleted irrigation table |
| Prog. No. | 92- The program that was added to the table was started manually. 93- The relevant irrigation was added to the uncompleted irrigations table for the second time (or more) consecutively. |
| VI. No. | Indicates the associated valve. If a group of valves that is configured to irrigate together is stopped, only the first valve is written but a '+' sign is added next to it to indicate that more valves are associated. |
| | The Green Field will attempt to complete the irrigations from the current day (until end day time) upon manual or automatic alarm reset. The valve column of irrigations that are to be completed will be highlighted. The valve column of irrigations that are currently being completed will blink. |
| Run No | Indicates the associated run time program. |
| Dose Prog. | Indicates the associated dosing program. |
| Prog. Qty. | Planned quantity according to the run time program. |
| Left Qty. | Uncompleted quantity. |

In order to manually stop an uncompleted irrigation you must go to the START/STOP VALVE in section 3.3 because the activation is according to single valves.

6.4 Uncompleted Programs

The Uncompleted Programs table provides information on programs that could not be completed. It is important to understand the difference between this table and the Uncompleted Irrigations table; this table consists only of irrigation cycles that haven't been started and could not be completed during the current day. This can happen due to wrong system setup (more tasks than could be completed), or because the system was not active for a long period of time, for example due to a power failure, and could not complete its tasks.

| UNCOMPLETED PROGRAMS | | | | | | |
|----------------------|--------|---------------|-------------|---------------|--------------|--------------|
| No. | Date | Time hh:mm | Prog No. | Start Time | Prog Cyc. | Left Cyc. |
| 4 | 9/Aug | 20:00 | 10 | 19:00 | 1 | 1 |
| 5 | 9/Aug | 21:00 | 10 | 20:00 | 1 | 1 |
| 6 | 10/Aug | 04:00 | 1 | 13:00 | 2 | 2 |
| 7 | 10/Aug | 05:00 | 1 | 04:00 | 2 | 2 |
| 8 | 10/Aug | 06:00 | 10 | 21:00 | 1 | 1 |
| 9 | 10/Aug | 07:00 | 1 | 05:00 | 2 | 2 |
| 10 | 10/Aug | 09:00 | 1 | 07:00 | 2 | 2 |
| 11 | 10/Aug | 11:00 | 1 | 09:00 | 2 | 2 |
| 12 | 10/Aug | 13:00 | 1 | 11:00 | 2 | 2 |
| 13 | 10/Aug | 14:00 | 10 | 06:00 | 1 | 1 |

The uncompleted program table consists of 200 lines.

6.5 Daily Irrigation

This table enable viewing history of irrigation quantities.

| DAILY IRRIGATION | |
|--------------------|-------------|
| How Many Days Ago? | ▶ 1 Day Ago |

Example: 1 day ago means you would like to view yesterday's history, and Today means you would like to view the accumulated history since the last End Day.



To open



the selection list



Relevant day using arrow keys



Current date viewed at top of screen.



| DATE : 20-Dec-06 | | | |
|------------------|--------|--------|---------|
| DAILY IRRIGATION | | | |
| Valve | Water | Drain% | Dra. Q. |
| 213 | 0.000 | 100 | 0.000 |
| 214 | 0.000 | 100 | 0.000 |
| 215 | 70.800 | 11 | 8.350 |
| 216 | 1.400 | 0 | 0.000 |
| 217 | 15.900 | 34 | 5.500 |
| 218 | 7.200 | 45 | 3.300 |
| 219 | 13.600 | 20 | 2.850 |
| 220 | 0.000 | 100 | 0.000 |
| 221 | 0.000 | 100 | 0.000 |

| DATE : 20-Dec-06 | | | |
|------------------|---------|---------|---------|
| DAILY IRRIGATION | | | |
| Valve | Chan. 1 | Chan. 2 | Chan. 3 |
| 213 | 0.00 | 0.00 | 0.00 |
| 214 | 0.00 | 0.00 | 0.00 |
| 215 | 211.36 | 211.37 | 211.37 |
| 216 | 3.93 | 3.94 | 3.94 |
| 217 | 30.87 | 30.82 | 30.83 |
| 218 | 19.06 | 19.97 | 18.12 |
| 219 | 25.25 | 26.01 | 24.49 |
| 220 | 0.00 | 0.00 | 0.00 |
| 221 | 0.00 | 0.00 | 0.00 |

Press +/- to Toggle Quantity/Time

Daily Irrigation table contains all water (m3 or gallon) and dosing (liter or gallon). To toggle the view between quantities and time, press the '+/-' key.

6.6 Irrigation Accumulation

The Irrigation Accumulation table allows you to accumulate water and dosing quantities for the required periods. The accumulation of each valve can be reset separately in the ACCUMULATION RESET table.

| DATE : 21-Dec-06 | | | |
|-------------------------|-----------|--------|---------|
| IRRIGATION ACCUMULATION | | | |
| Valve | Date | Water | Chan. 1 |
| 214 | 20-Dec-06 | 0.000 | 0.00 |
| 215 | 20-Dec-06 | 70.800 | 211.36 |
| 216 | 20-Dec-06 | 1.400 | 3.93 |
| 217 | 20-Dec-06 | 19.100 | 35.28 |
| 218 | 20-Dec-06 | 7.200 | 19.06 |
| 219 | 20-Dec-06 | 16.800 | 29.65 |
| 220 | 20-Dec-06 | 0.000 | 0.00 |
| 221 | 20-Dec-06 | 0.000 | 0.00 |
| 222 | 20-Dec-06 | 0.000 | 0.00 |

Press +/- to Toggle Quantity/Time

| DATE : 21-Dec-06 | | | |
|-------------------------|---------|---------|---------|
| IRRIGATION ACCUMULATION | | | |
| Valve | Chan. 1 | Chan. 2 | Chan. 3 |
| 214 | 0.00 | 0.00 | 0.00 |
| 215 | 211.36 | 211.37 | 211.37 |
| 216 | 3.93 | 3.94 | 3.94 |
| 217 | 35.28 | 35.21 | 35.21 |
| 218 | 19.06 | 19.97 | 18.12 |
| 219 | 29.65 | 30.38 | 28.86 |
| 220 | 0.00 | 0.00 | 0.00 |
| 221 | 0.00 | 0.00 | 0.00 |
| 222 | 0.00 | 0.00 | 0.00 |

Press +/- to Toggle Quantity/Time

To toggle the view between quantities and time, press the '+/-' key

Water quantity is measured in cubic meter or gallons; dosing quantity is measured in liters or gallons

6.7 Aux Meter Accumulation

The Auxiliary Meter Accumulation table allows you to accumulate quantities from meters that do not have designated software, for example, in order to measure the drain water quantity or to measure the cooling system's consumption.

| AUX METER ACCUMULATION | | |
|------------------------|----------|-----------|
| Meter | Quantity | Date |
| 1 | 4.600 | 20-Dec-06 |
| 2 | 3.500 | 20-Dec-06 |
| 3 | 2.200 | 20-Dec-06 |
| 4 | 2.500 | 20-Dec-06 |
| 5 | 3.450 | 20-Dec-06 |
| 6 | 3.600 | 20-Dec-06 |
| 7 | 5.700 | 20-Dec-06 |
| 8 | 4.200 | 20-Dec-06 |

NOTE Water meters are accumulators only and are not a part of the irrigation control.

To reset an auxiliary meter refer to the ACCUMULATION {XE "Reset Total Quantity" } table below.

The quantities displayed are in liters (gallons) up to 9999.999.

6.8 Accumulation Reset

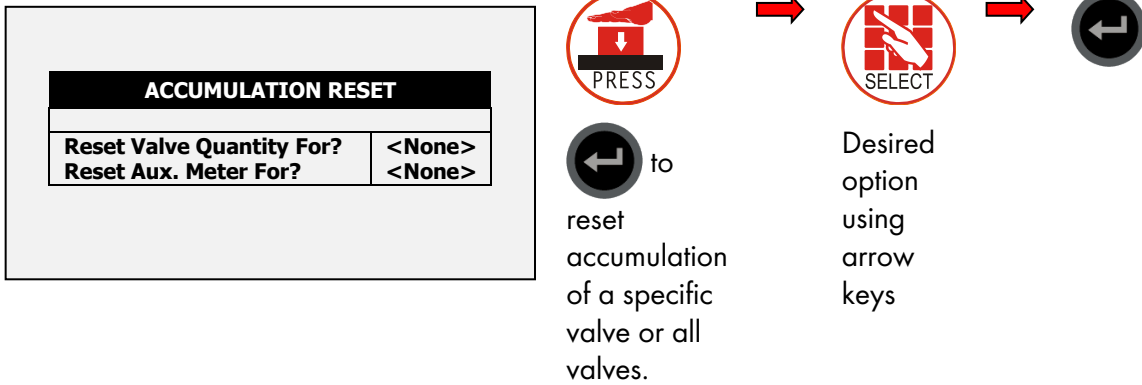

NOTE When resetting a valve (or all valves), its history is erased from the Daily Irrigation and Irrigation Accumulation tables:

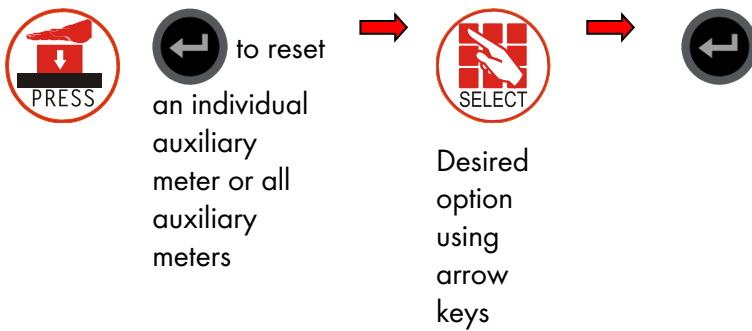

NOTE When resetting an Aux meter (or all Aux meters), its history will be erased from the Aux Meter Accumulation table.

6.9 Filters

The filters history table provides daily information of the number and cause of flushing.

| FILTERS | | | |
|---------|----------|------|--------|
| Date | Delta P. | Time | Manual |
| 10/Aug | 0 | 44 | 0 |
| 9/Aug | 0 | 0 | 0 |
| 8/Aug | 0 | 0 | 0 |

6.10 Cooling

Viewing the history of cooling activities or time per valve is allowed.

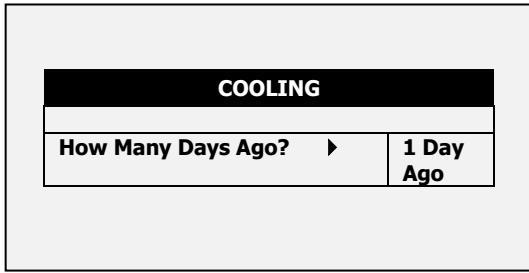

 to
open
selection list

Relevant day
using arrow
keys

| COOLING | | | |
|-----------|------------|----------|--------|
| Prog. No. | From hh:mm | To hh:mm | Cycles |
| 1 | 13:10 | 18:14 | 60 |
| 2 | 13:13 | 18:14 | 9 |
| 3 | --:-- | --:-- | ---- |
| 4 | --:-- | --:-- | ---- |
| 5 | --:-- | --:-- | ---- |
| 6 | --:-- | --:-- | ---- |
| 7 | --:-- | --:-- | ---- |
| 8 | --:-- | --:-- | ---- |

For example, 1 day ago means you would like to view yesterday's history, and Today means you would like to view the accumulated history since the last End Day.

6.11 Sensor Log

The Sensors Log table includes history of average measurements of logged sensors. In order to define which sensor to log, the user should access menu 6.8 – Sensor Logging, and mark by +/- button the required sensor.

In order to define the measurement interval, the user should go to menu 6.2 and choose the required History resolution.

| SENSORS LOG | | | | |
|-------------|-------|-----------|--------|--------|
| Date | Time | Avg. Hum. | Temp-1 | Temp-2 |
| 10/Aug | 16:28 | 22.7 | 22.7 | ---- |
| 10/Aug | 16:27 | 22.7 | 22.7 | ---- |
| 10/Aug | 16:26 | 22.7 | 22.7 | ---- |
| 10/Aug | 16:26 | 22.7 | 22.7 | ---- |
| 10/Aug | 16:25 | 22.7 | 22.7 | ---- |
| 10/Aug | 16:24 | 22.7 | 22.7 | ---- |
| 10/Aug | 16:23 | 22.7 | 22.7 | ---- |
| 10/Aug | 16:22 | 22.7 | 22.7 | ---- |
| 10/Aug | 16:20 | 22.7 | 22.7 | ---- |

The Sensors Log table contains up to 10,000 data fields. Date and time are two fields per line and every sensor is an additional field.

For example: logging of two sensors uses four data fields; two for time and date and one for each sensor. In this case, the table will consist of a maximum of 2,500 lines.

6.12 Event Log

The table provides information of all the processes performed by the Green Field including their time and date.

| EVENT LOG | | | |
|-----------|-----------------------|--------|-------|
| No. | Event | Date | Time |
| 1 | Water Leak # 4 | 20/Dec | 09:01 |
| 2 | Program # 1 Manual On | 20/Dec | 09:03 |
| 3 | Valve #51 Manual Off | 20/Dec | 09:04 |
| 4 | Program # 1 Man. Off | 20/Dec | 09:04 |
| 5 | Program # 1 Manual On | 20/Dec | 09:04 |
| 6 | Valve #51 Low Flow | 20/Dec | 09:04 |
| 7 | Program # 1 Man. Off | 20/Dec | 09:05 |
| 8 | Program # 2 Rad. On | 20/Dec | 09:21 |
| 9 | Valve # 1 High Flow | 20/Dec | 09:23 |
| 10 | Program # 2 Rad. Off | 20/Dec | 09:25 |

6.13 System Log

This table provides information of all the system changes.

| SYSTEM LOG | | | |
|------------|-----------------------|--------|-------|
| No. | Event | Date | Time |
| 1 | PC Irri. Prog #10 Ch. | 20/Dec | 09:01 |
| 2 | Reset Alarm | 20/Dec | 09:03 |
| 3 | PC Table #1.3 Change | 20/Dec | 09:04 |
| 4 | PC Irri. Prog #1 Ch. | 20/Dec | 09:04 |
| 5 | PC Irri. Prog #1 Ch. | 20/Dec | 09:04 |
| 6 | Irrig. Prog #1 Ch. | 20/Dec | 09:04 |
| 7 | Irrig. Prog #2 Ch. | 20/Dec | 09:05 |
| 8 | Table #7.7 Change | 20/Dec | 09:21 |
| 9 | Table #1.3 Change | 20/Dec | 09:23 |
| 10 | Table #1.7 Change | 20/Dec | 09:25 |

The table consists of the last 999 events

Examples of system changes are changes of triggered by the controller, the PC communication, a power off, etc.

7 Warranty

Warranty and technical assistance

Munters products are designed and built to provide reliable and satisfactory performance but cannot be guaranteed free of faults; although they are reliable products they can develop unforeseeable defects and the user must take this into account and arrange adequate emergency or alarm systems if failure to operate could cause damage to the articles for which the Munters plant was required: if this is not done, the user is fully responsible for the damage which they could suffer.

Munters extends this limited warranty to the first purchaser and guarantees its products to be free from defects originating in manufacture or materials for one year from the date of delivery, provided that suitable transport, storage, installation and maintenance terms are complied with. The warranty does not apply if the products have been repaired without express authorisation from Munters, or repaired in such a way that, in Munters' judgement, their performance and reliability have been impaired, or incorrectly installed, or subjected to improper use. The user accepts total responsibility for incorrect use of the products.

The warranty on products from outside suppliers fitted to Green Field, (for example Green Field's antennas, power supplies, cables, etc.) is limited to the conditions stated by the supplier: all claims must be made in writing within eight days of the discovery of the defect and within 12 months of the delivery of the defective product. Munters has thirty days from the date of receipt in which to take action, and has the right to examine the product at the customer's premises or at its own plant (carriage cost to be borne by the customer).

Munters at its sole discretion has the option of replacing or repairing, free of charge, products which it considers defective, and will arrange for their despatch back to the customer carriage paid. In the case of faulty parts of small commercial value which are widely available (such as bolts, etc.) for urgent despatch, where the cost of carriage would exceed the value of the parts, Munters may authorise the customer exclusively to purchase the replacement parts locally; Munters will reimburse the value of the product at its cost price.

Munters will not be liable for costs incurred in demounting the defective part, or the time required to travel to site and the associated travel costs. No agent, employee or dealer is authorised to give any further guarantees or to accept any other liability on Munters' behalf in connection with other Munters products, except in writing with the signature of one of the Company's Managers.

WARNING: In the interests of improving the quality of its products and services, Munters reserves the right at any time and without prior notice to alter the specifications in this manual.

The liability of the manufacturer Munters ceases in the event of:

- dismantling the safety devices;
- use of unauthorised materials;
- inadequate maintenance;
- use of non-original spare parts and accessories.

Barring specific contractual terms, the following are directly at the user's expense:

- preparing installation sites;
- providing an electricity supply (including the protective equipotential bonding (PE) conductor, in accordance with CEI EN 60204-1, paragraph 8.2), for correctly connecting the equipment to the mains electricity supply;
- providing ancillary services appropriate to the requirements of the plant on the basis of the information supplied with regard to installation;
- tools and consumables required for fitting and installation;
- lubricants necessary for commissioning and maintenance.

It is mandatory to purchase and use only original spare parts or those recommended by the manufacturer.

Dismantling and assembly must be performed by qualified technicians and according to the manufacturer's instructions.

The use of non-original spare parts or incorrect assembly exonerates the manufacturer from all liability.

Requests for technical assistance and spare parts can be made directly to the nearest [Munters office](#).

