

Multifan



Greenhouse Fan

The new generation!



VOSTERMANS
VENTILATION

YOUR SPECIALIST IN AIR

Multifan Greenhouse Fan

The next generation of Greenhouse Fans

With the new Multifan Greenhouse fan, you can create a uniform greenhouse climate while minimizing energy consumption. The improved fan design offers a number of important advantages. For example, the energy efficiency of the fan has been greatly improved, and it is much quieter. It is also easier to attach air hoses to the fan, saving you installation costs and making the fan cheaper to use. Create the ideal growing climate for your crop with this compact, powerful fan, which was specifically developed for the horticultural sector.



Why choose this fan

- Powerful, quiet fan
- Among the most energy efficient in its class
- Low investment costs
- Easy to install
- Easy to maintain
- Completely white version for the ideal growing climate
- Materials resistant to extreme conditions
- Long service life: 3-year guarantee



Features

- Available in 3 versions: 5,000, 7,000 and 8,500 m³/h
- Motor insulation class F.
- IP55 motor (water-resistant and dust-resistant)
- Energy efficient, up to 22.6 W/1,000 m³/h
- Low noise, up to 46 dB(A)
- Simple to attach 52 cm diameter air hoses
- Built-in thermal protection for single-phase motors

Applications

- Greenhouse horticulture
- Agricultural: pigs, poultry, dairy cattle
- Industry

Options available

- CE wire-guard kit (affects the performances)
- 5-meter cable with plug
- Built-in thermal detectors for 3-phase motors
- Frequency-controlled motor



45 cm Greenhouse Fan



Simple to attach air hoses

Technical data single-phase

Article	ø (cm)	Power supply			(n) RPM	P _{in} (W)	I _{nom} (A)	Q _v (m ³ /h)	Throw (m)*	SFP @0Pa (W/1000m ³ /h)	dB(A) **	Control options ***
		~	V	Hz								
T6E45AAM80100	45	1	230	50	950	110	0,6	4.800	45	24,8	46	E/T
T4E45DAM80100	45	1	230	50	1.460	190	0,9	6.450	55	29,8	55	E/T
T4E45BAM80100	45	1	230	50	1.450	250	1,2	6.950	60	35,8	55	E/T
T4E45CAM80100	45	1	230	50	1.415	370	1,7	8.700	65	42,9	54	E/T
T6E45KAM80100	45	1	230	60	1.125	120	0,6	5.000	45	23,8	49	E/T
T4E45LBM80100	45	1	115	60	1.735	270	2,4	7.150	60	37,9	58	E/T
T4E45LAM80100	45	1	230	60	1.740	280	1,2	7.150	60	38,2	59	E/T
T4E45MAM80100	45	1	230	60	1.655	390	1,8	8.450	65	46,9	58	E/T

Technical data three-phase

Article	ø (cm)	Power supply			(n) RPM	P _{in} (W)	I _{nom} (A) Y	Q _v (m ³ /h)	Throw (m)*	SFP @0Pa (W/1000m ³ /h)	dB(A) **	Control options ***
		~	V (Y)	Hz								
T6D45AAM80100	45	3	400	50	975	110	0,5	5.000	45	22,6	47	T
T4D45BAM80100	45	3	400	50	1.460	230	0,8	6.950	60	33,0	54	T
T4D45CAM80100	45	3	400	50	1.425	370	0,9	8.750	65	42,6	54	T
T4D45DAM80100	45	3	400	50	1.415	450	1,1	9.250	69	48,6	55	T
T6D45KAM80100	45	3	460	60	1.175	130	0,5	5.200	45	24,6	49	T
T4D45LAM80100	45	3	460	60	1.755	270	0,7	7.250	60	37,3	58	T
T4D45MAM80100	45	3	460	60	1.720	410	0,8	8.850	65	45,7	59	T

- * Recommended throw based on field tests without wire guard.
- ** Sound pressure level calculated at 7 meter free blowing distance.
- *** Controllable by Transformer (T), Frequency Controllable (F), Controllable by Triac (E)

Dimensions (mm)

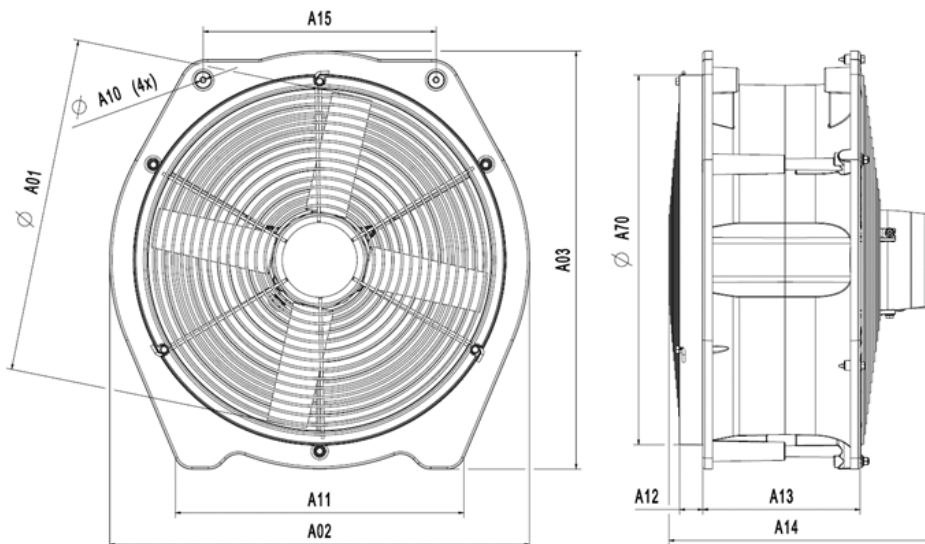

ø (cm)	A01	A02	A03	A10	A11	A12	A13	A14	A15	A70
45	472	586	586	6,5	403	32	220	368	326	520



More than 65 years of experience

The 'Venlo Greenhouse' is perhaps the most famous type of greenhouse worldwide. So it is hardly a coincidence that we have been active in the horticultural sector since the early years

of Vostermans Ventilation. As a result, we have gained a lot of knowledge with which we can support you in finding the right ventilation solution for your business.

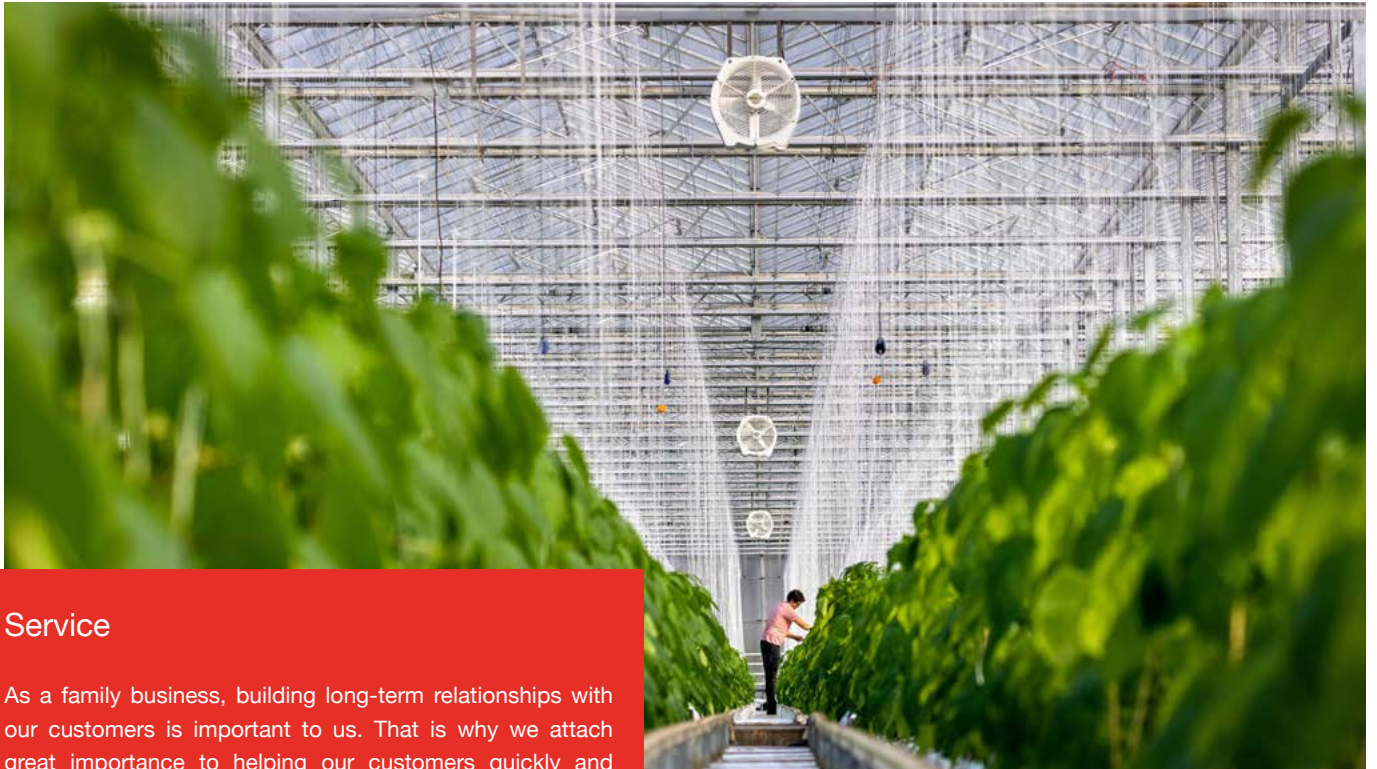

Service

As a family business, building long-term relationships with our customers is important to us. That is why we attach great importance to helping our customers quickly and effectively when a problem arises. Do you have a question or need support? Please contact our Customer Service Team using the contact details below.

Why choose Vostermans Ventilation:

LOYAL TO YOU

We care for your specific needs based on our long expertise. In close cooperation with you we secure your business outcomes.

RELIABLE

Since our foundation in the Netherlands in 1952, we maintain our reputation as reliable partner. Our carefully selected global network of independent distributors strive to deliver you dedicated service and expertise.

FUTURE PROOF

Our future proof approach, which combines energy efficiency solutions with robust quality and rigorous testing, is based on a genuine commitment to serve as a trusted partner.

Vostermans Ventilation is a global developer and manufacturer of sustainable axial fans for the agricultural and industrial market. Sustainability is key for Vostermans. Their premium brandlines Multifan and EMI are showcasing the drive for advanced energy efficient fans. The company applies continuous innovation and research in their own motor production facility and in house state of the art R&D department. Vostermans Ventilation, part of Vostermans Companies founded in 1952, is based in Venlo, the Netherlands and operates in USA, China and Malaysia.



YOUR SPECIALIST IN AIR

All rights reserved. Vostermans Companies is not responsible for inaccurate or incomplete data. In case of any questions and / or remarks please contact ventilation@vostermans.com. Subject to alterations 05/2023

Venlo - The Netherlands
Tel. +31 (0)77 389 32 32
ventilation@vostermans.com

Bloomington, IL- USA
Tel. +1 309 827-9798
ventilation@vostermansusa.com

Tmn Klang Jaya - Malaysia
Tel. +60 (0)3 3324 3638
ventilation@vostermansasia.com

Shanghai - China
Tel. +86 21 5290 2889/2899
ventilation@vostermanschina.com